



Locales comerciales



Pórticos comercio



PLANTA PÚBLICA
ESC. 1:250



Hall recepción



Fachada este



PLANTA TIPO PISO 2 Y 3
ESC. 1:250



CORTE TRANSVERSAL
ESC. 1:250

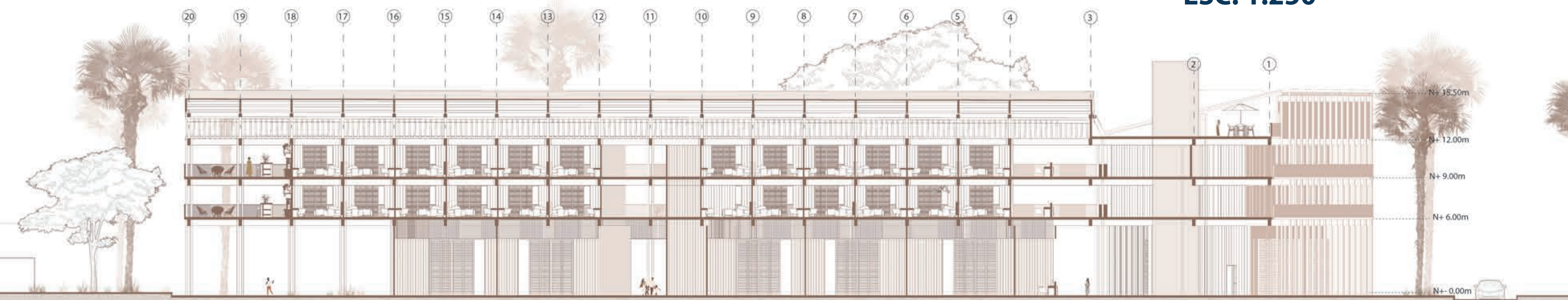

CORTE LONGITUDINAL
ESC. 1:250

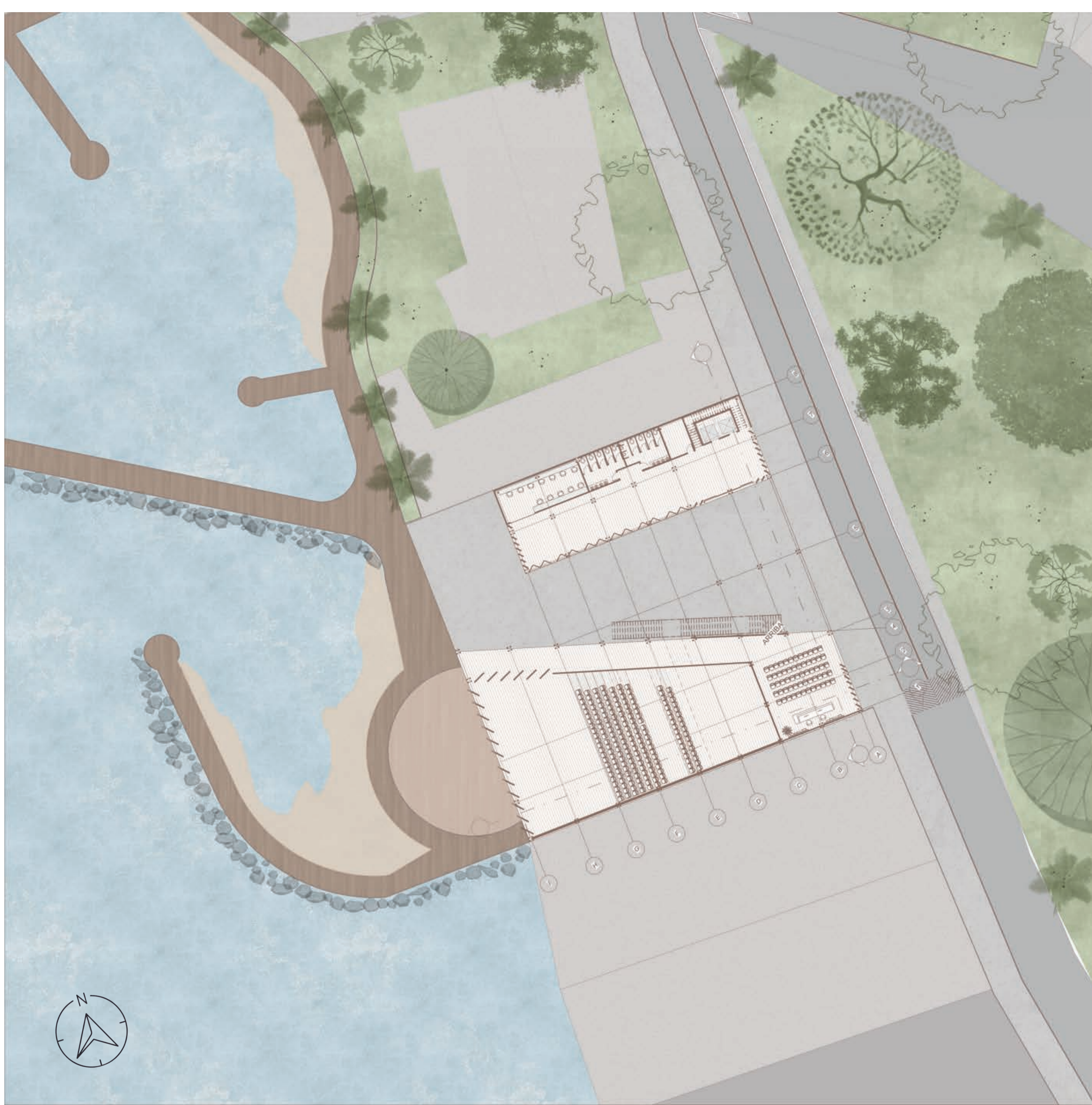

PLANTA PÚBLICA
ESC. 1:250

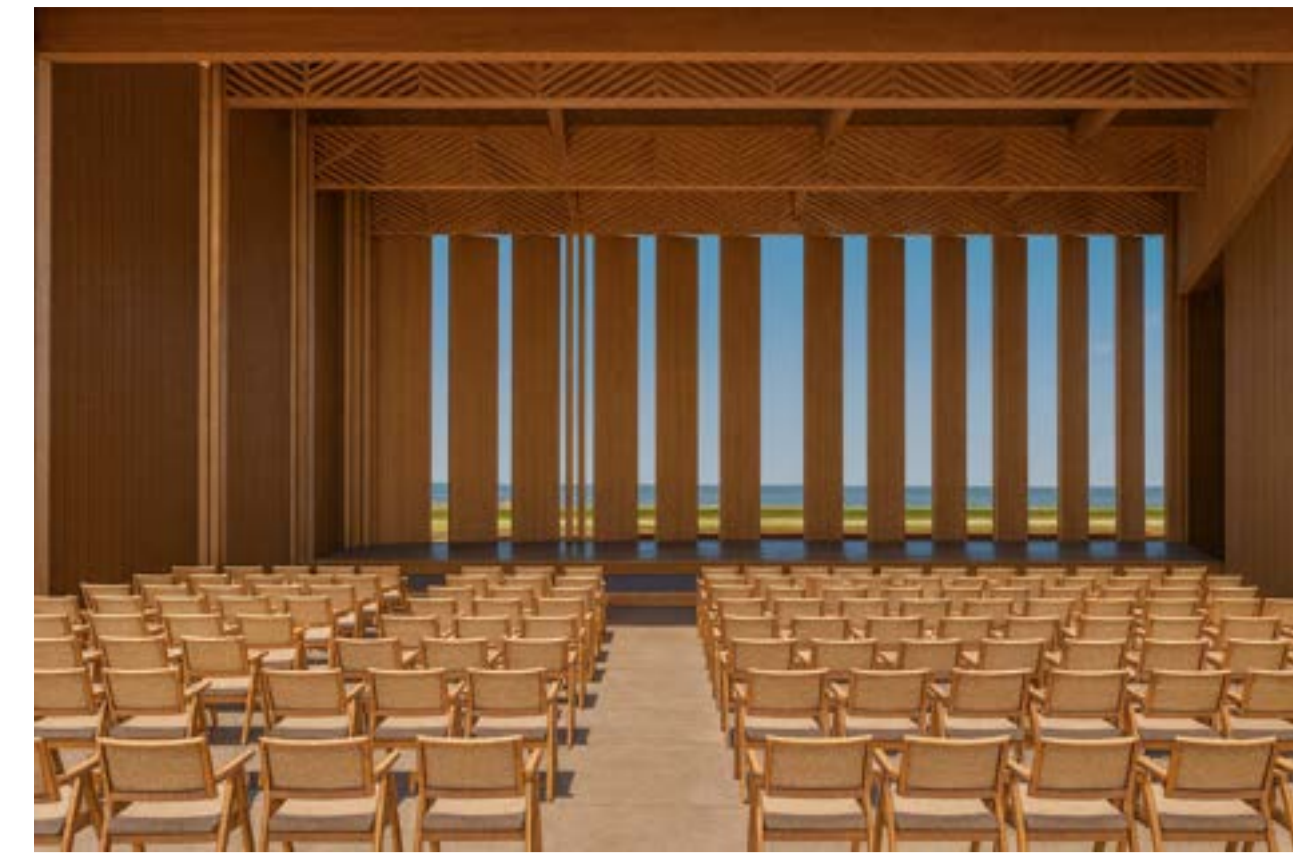

Auditorio principal



Oficinas admin

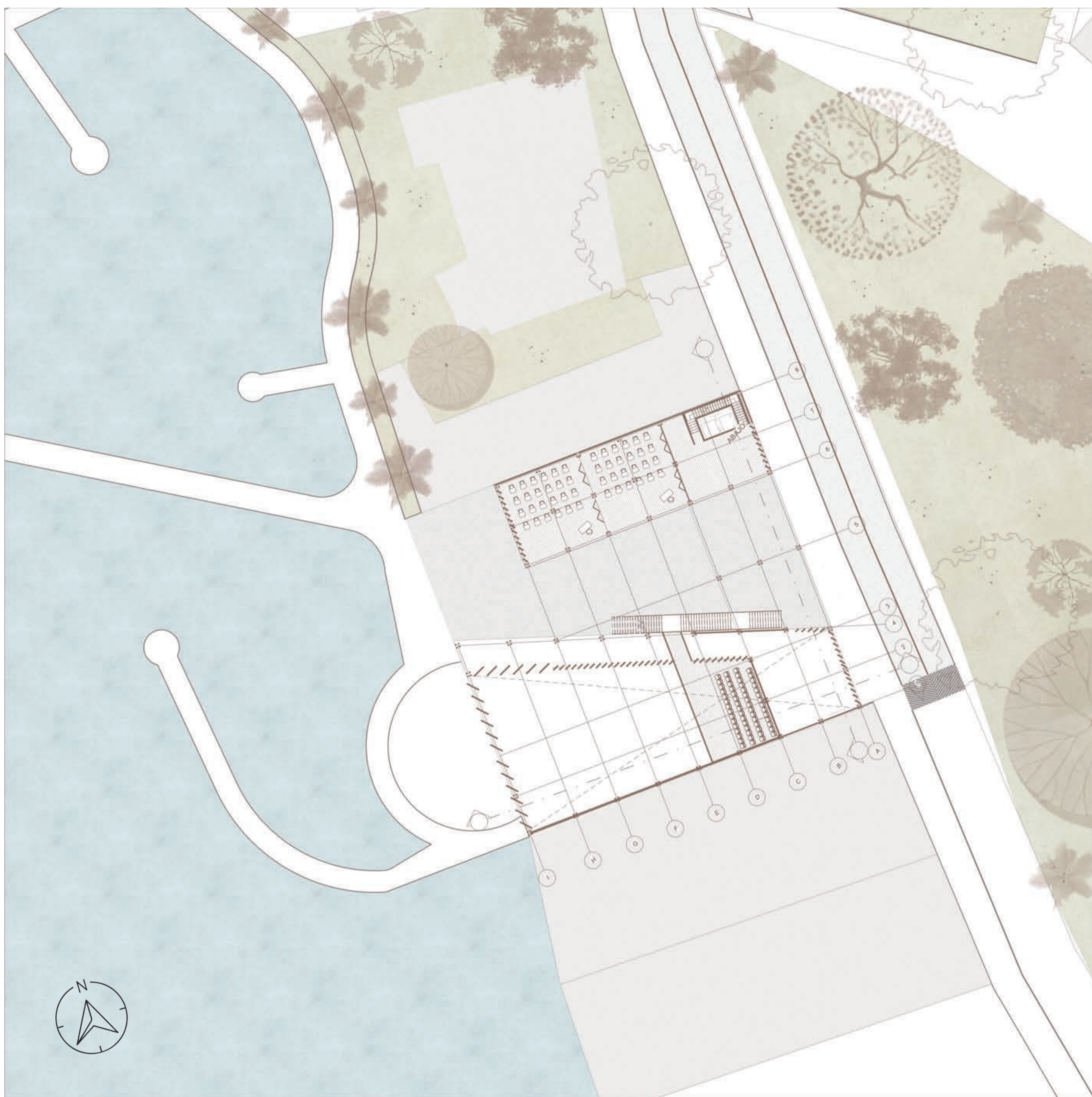

PLANTA TIPO PISO 2
ESC. 1:250



Terrazas



Acceso principal



CORTE TRANSVERSAL
ESC. 1:200



Salones de clase



CORTE TRANSVERSAL
ESC. 1:500



Acceso principal



Malecón

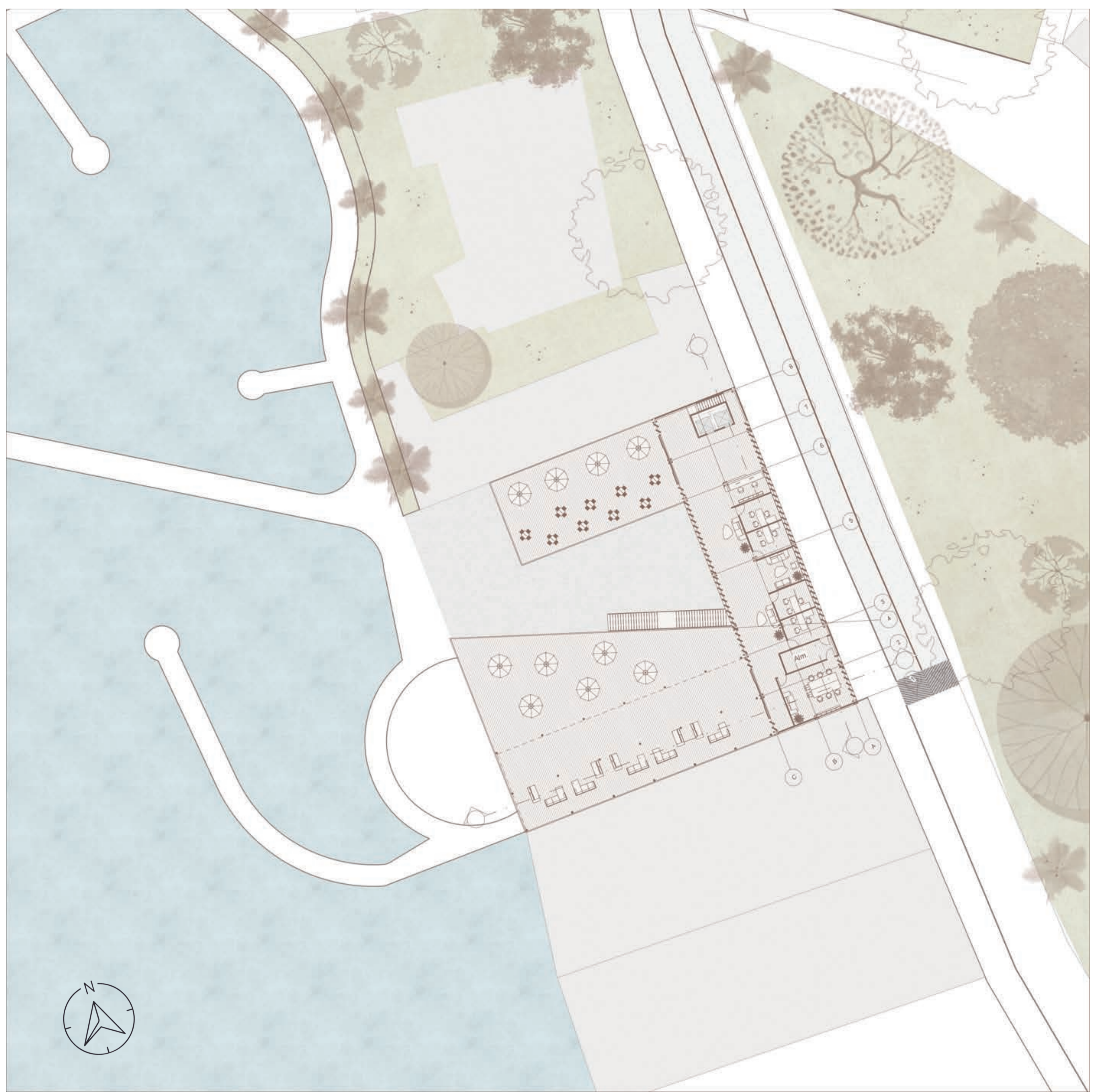

PLANTA TIPO PISO 3
ESC. 1:250

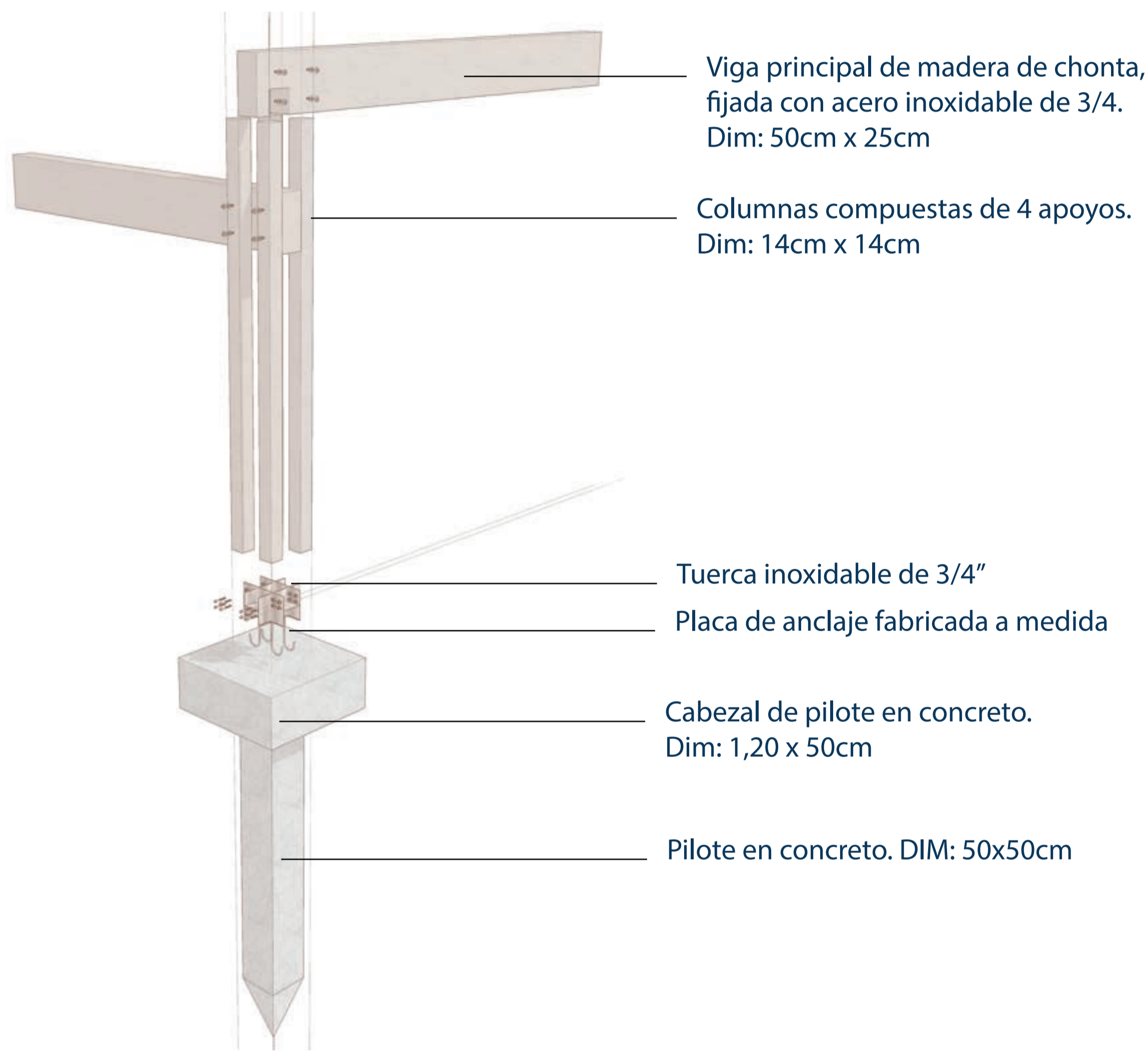

CORTE TRANSVERSAL
ESC. 1:200

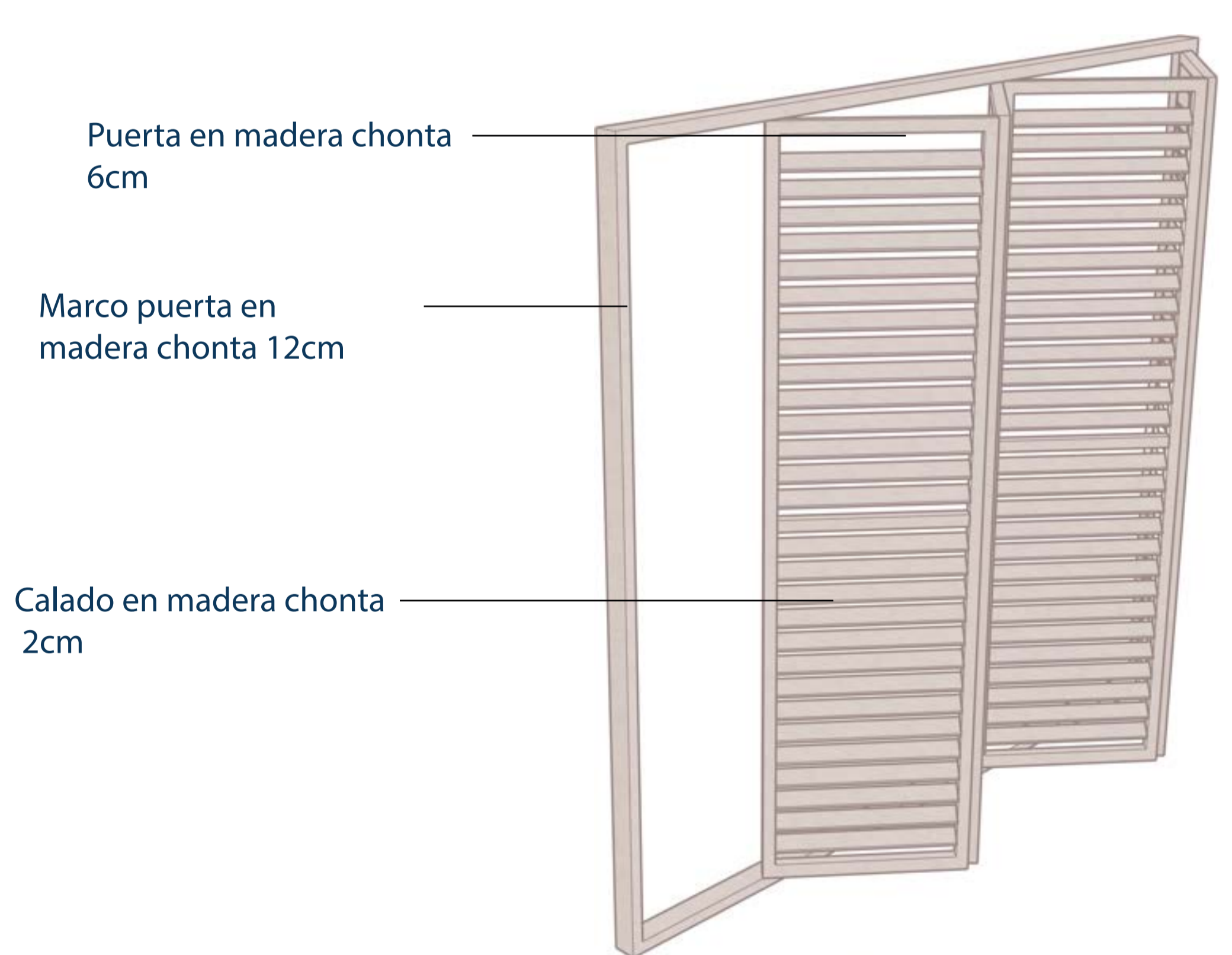
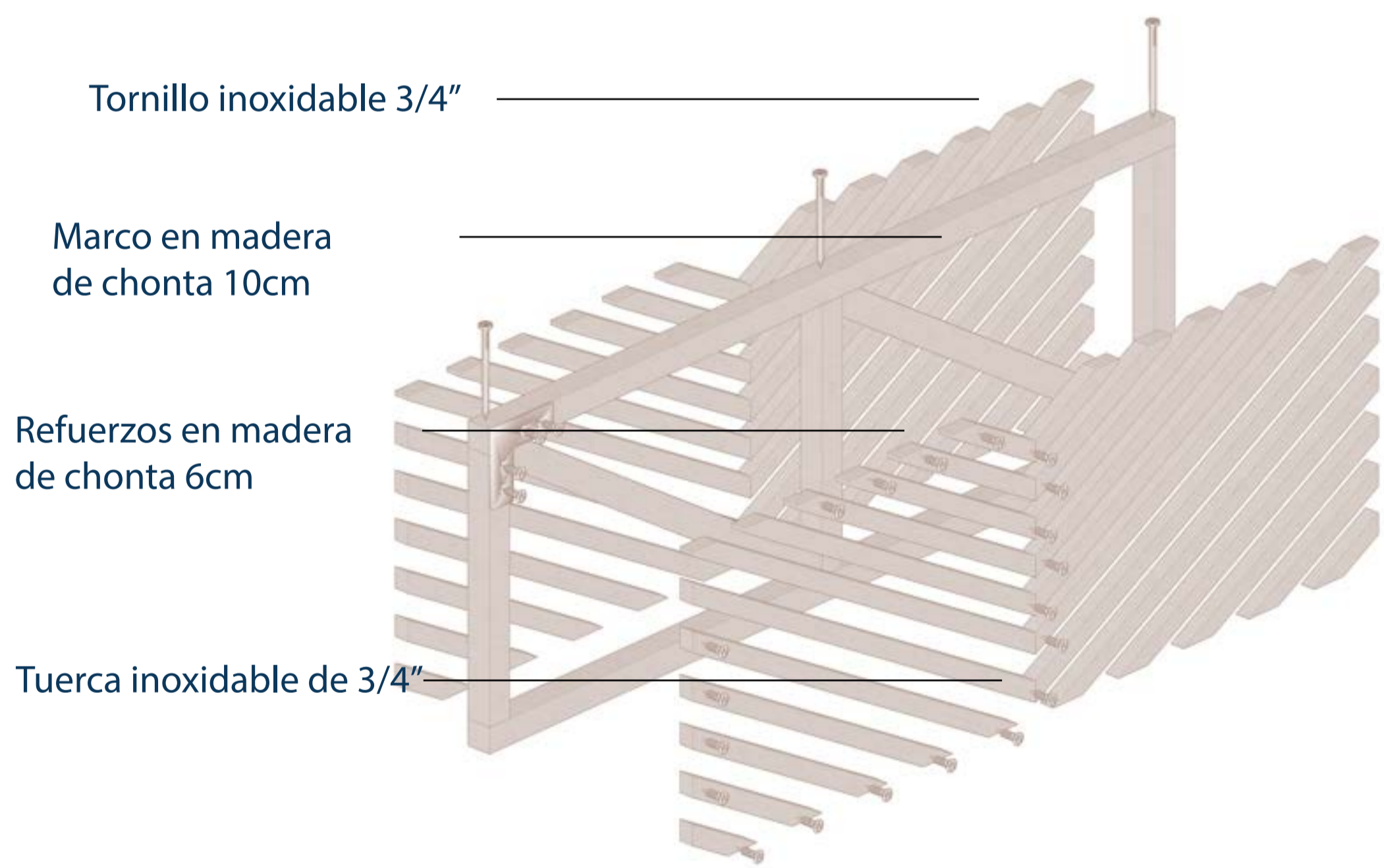

CUBIERTA MADERA DE CHONTA
RECUBRIMIENTO TEJA SHINGLE ROJA x 18CM

COLUMNA 4 APOYOS X 14CM x 14CM

CANAL RECOLECC. AGUA LLUVIA X 10CM

MURO MADERA DE CHONTA -
DOBLE CARA X 12CM

PUERTAS PLEGABLES,
MADERA DE CHONTA X12CM

VIGA MADERA DE CHONTA X 50CM x 25CM

MURO MADERA DE CHONTA - 1 CARA X 9CM

LOSA DE PISO - MICROCEMENTO X 18CM



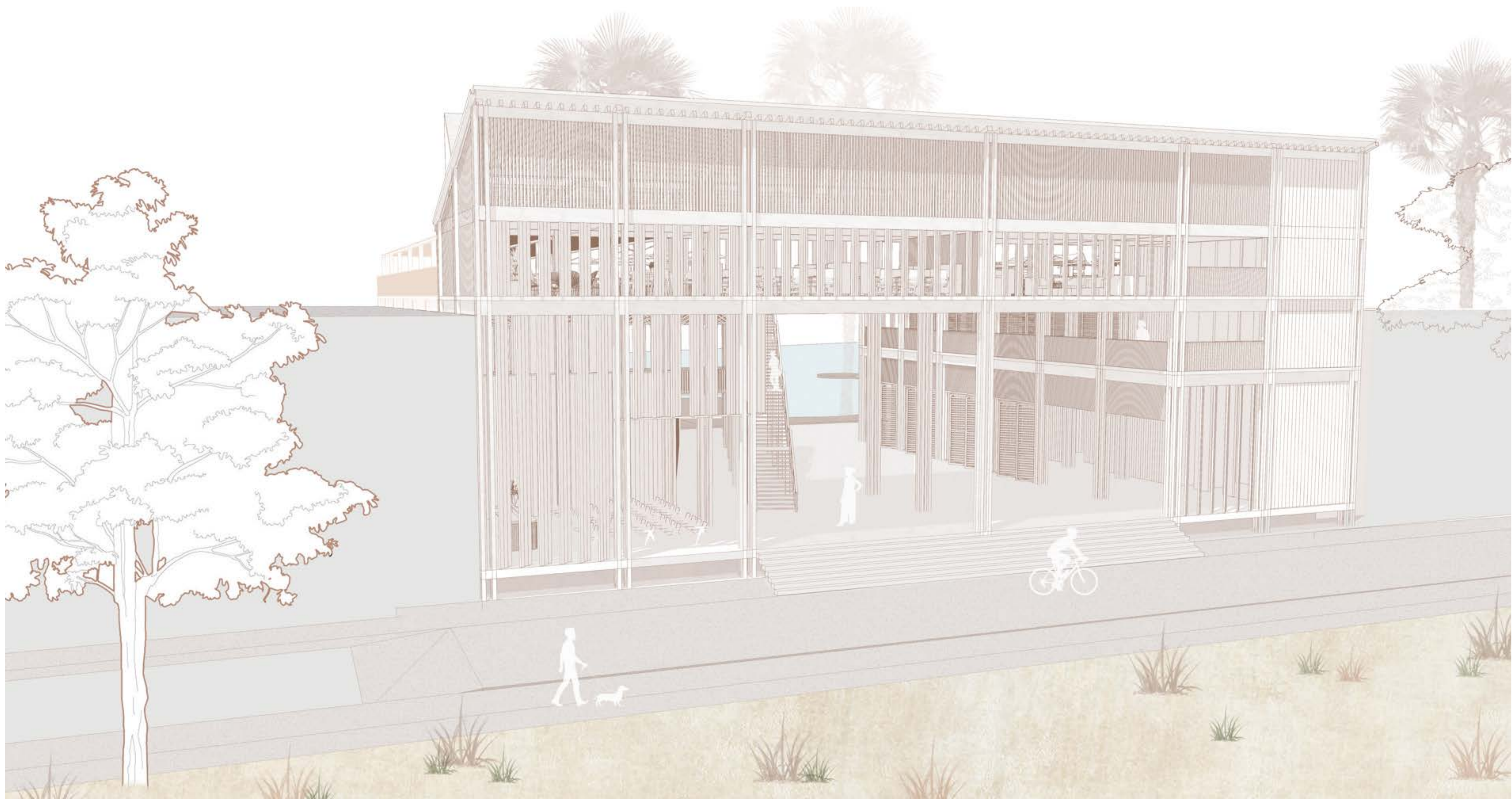

FACHADA ESTE

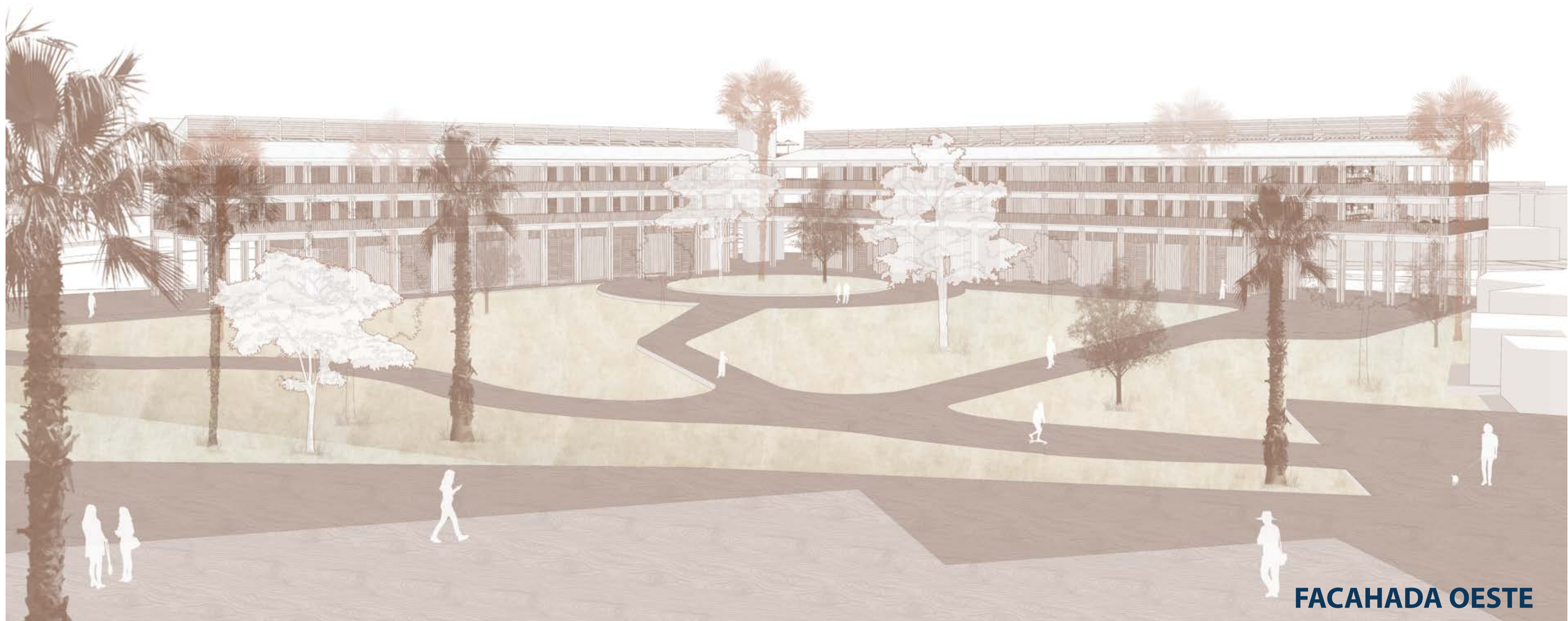

FACHADA OESTE

