

LAS CONTRADICCIONES EN EL USO DEL ESPACIO PÚBLICO EN EL BARRIO BOCHALEMA, SANTIAGO DE CALI

Maria Camila Sánchez Hormiga

Directora: Sabina Cárdenas O'Byrne

Pontificia Universidad Javeriana Cali



CONTENIDO



01

PROBLEMÁTICA

03

CUATRO COMPONENTES

02

METODOLOGÍA

04

CONCLUSIONES

01. PROBLEMÁTICA

CRECIMIENTO
POBLACIONAL
ACCELERADO

Desarrollo sin la
completa
participación de la
planificación
urbana

DÉFICIT DE
ESPACIO
PÚBLICO

Según la OMS, el
espacio público por
habitante debe ser
mínimo de 15
metros cuadrados

PLAN PARCIAL
DE EXPANSIÓN
BOCHALEMA

Administración
municipal de Cali
junto al
Departamento de
Planeación

ESPACIO
PÚBLICO QUE
NO SE USA

Parques que se
desarrollaron
siguiendo el primer
Plan de Ordenamiento
Territorial de la
ciudad

02. LOCALIZACIÓN

SANTIAGO DE CALI, BARRIO BOCHALEMA

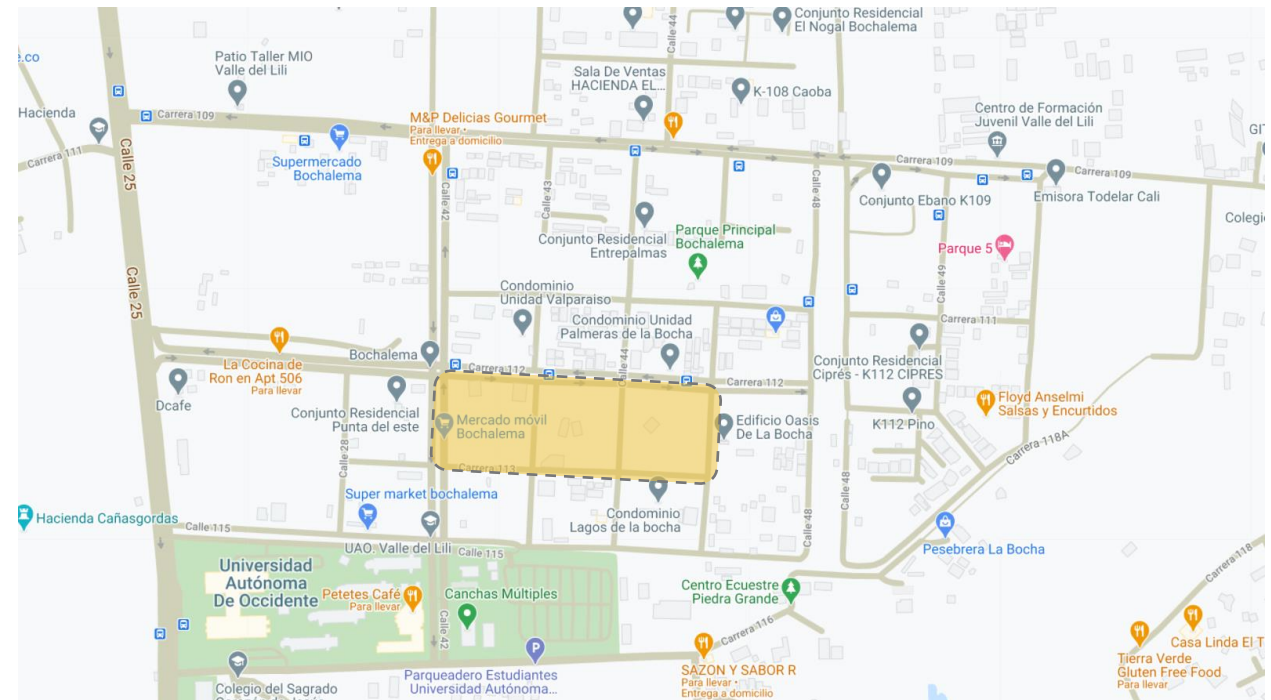
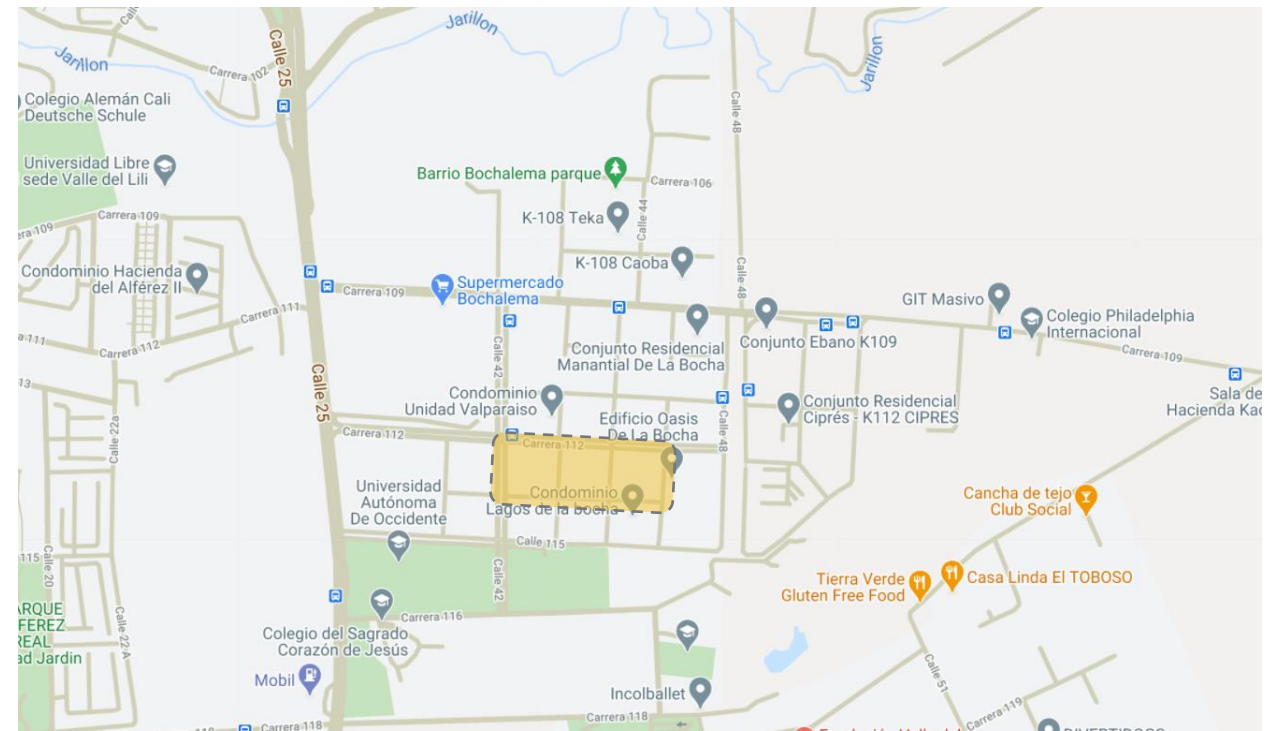
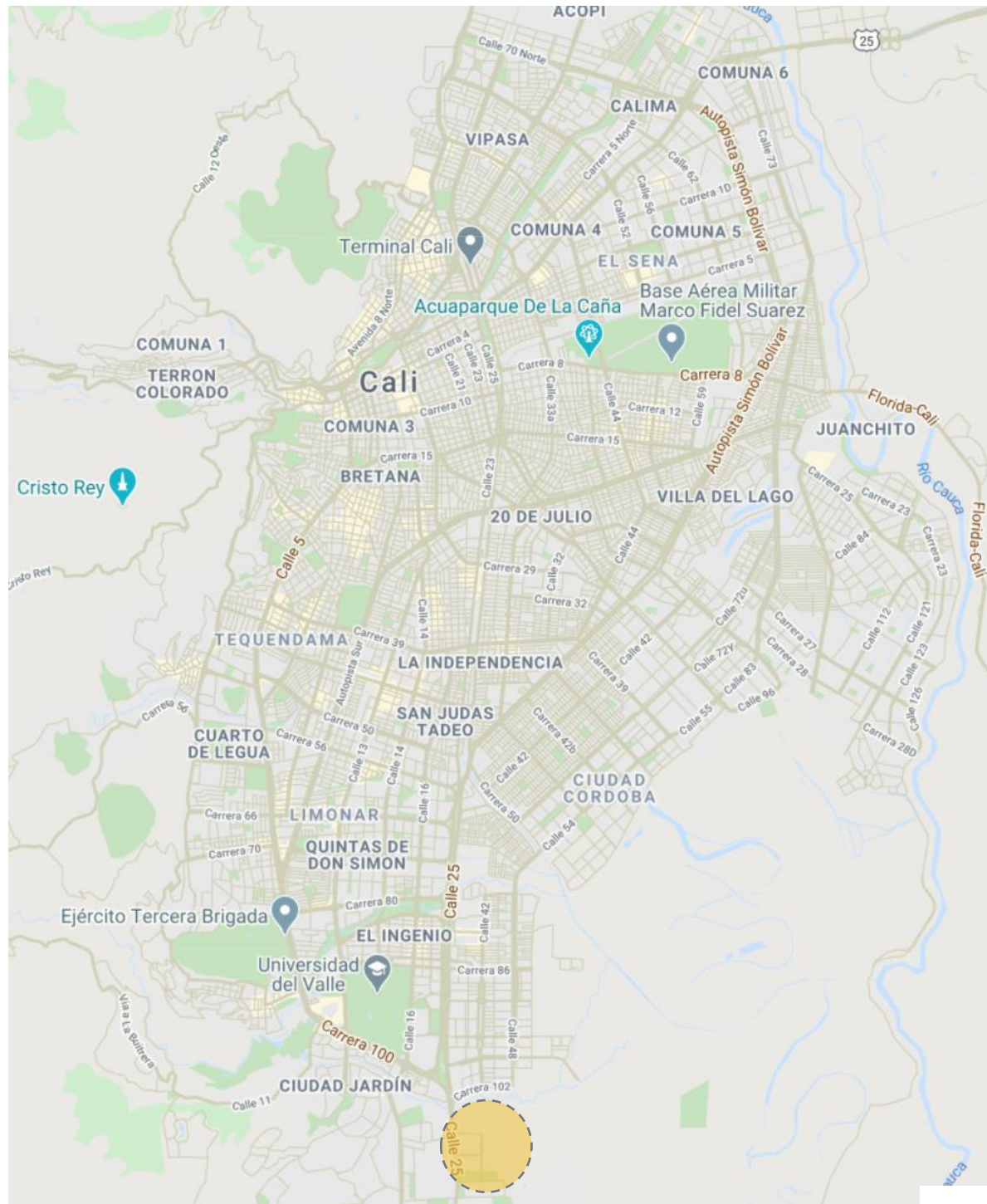

02. METODOLOGÍA

PROTOS, MAPA DE CALOR, DIAGRAMAS



PROTOCOLO TRAZABILIDAD



DIAGRAMA PROTOCOLO TRAZABILIDAD



PROTOCOLO AGRUPACIÓN Y DISPERSIÓN

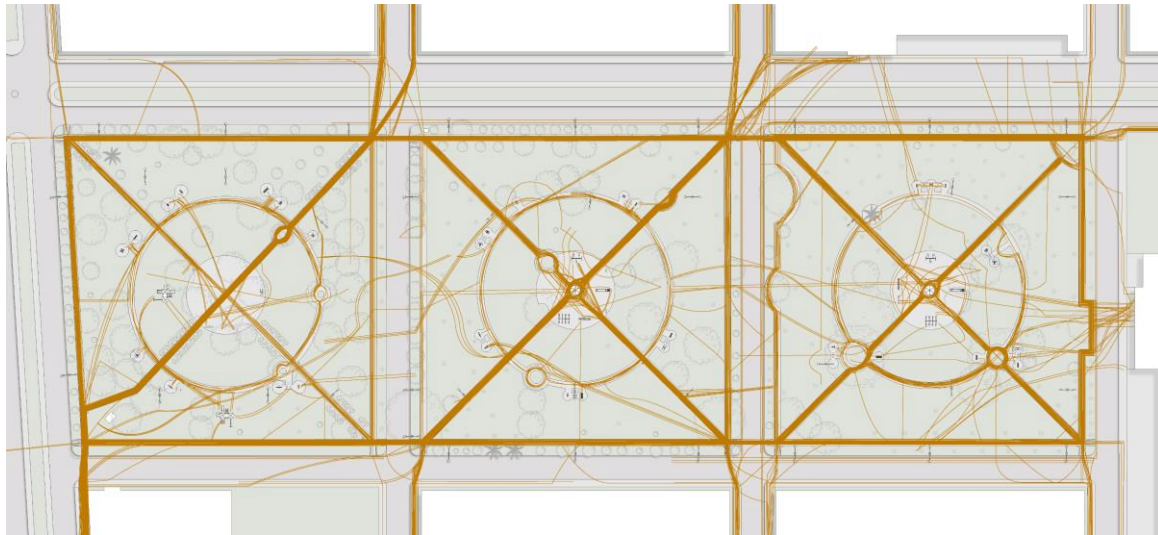
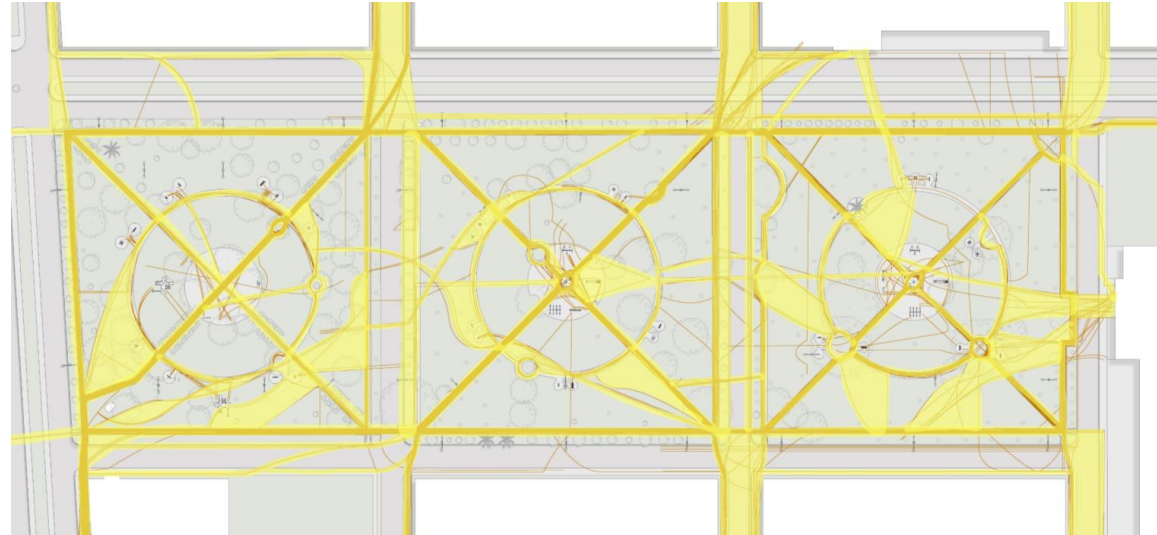

DIAGRAMA PROTOCOLO AGRUPACIÓN Y DISPERSIÓN



LOS CUATRO COMPONENTES SEGÚN EL DECRETO NACIONAL 1077 DE 2015

1. ACCESIBILIDAD

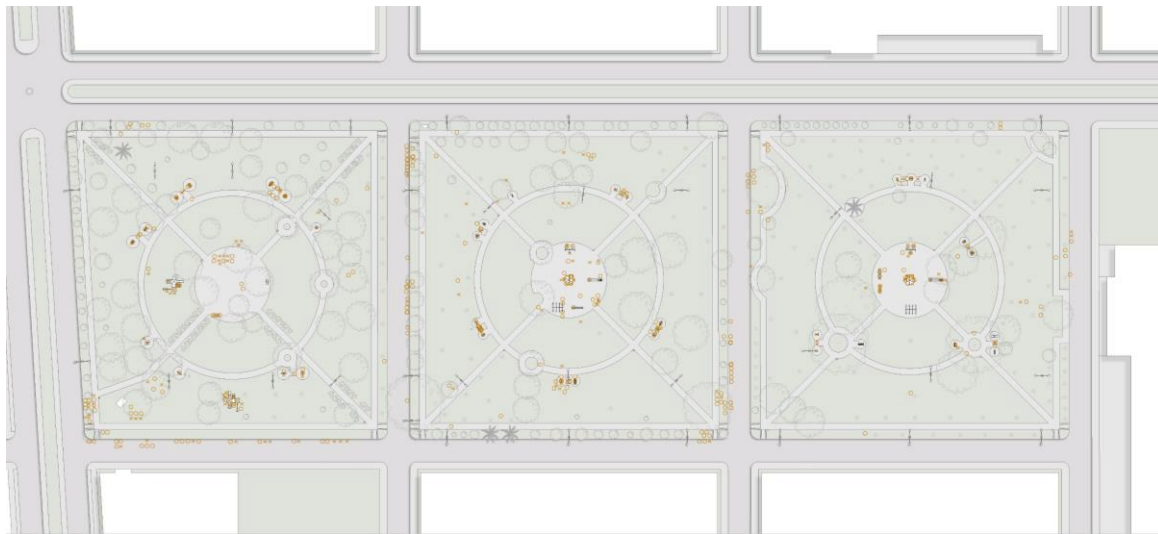
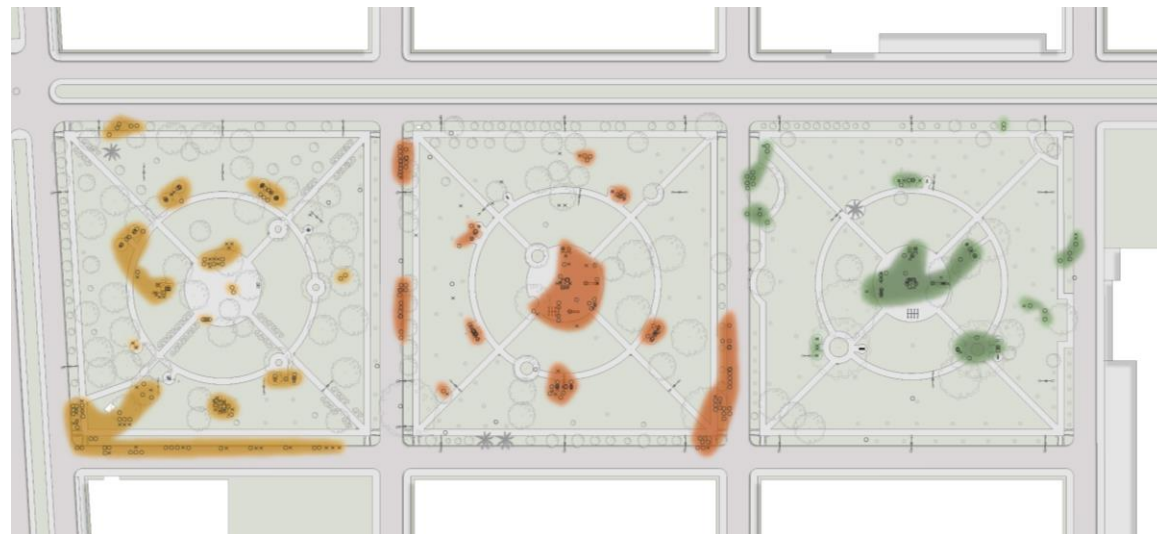
3. SEGURIDAD

2. DOTACIÓN

4. CONFORT





03. ACCESIBILIDAD

PASO SEGURO, POMPEYANO

PROTOCOLO TRAZABILIDAD

PLANTA PROPUESTA

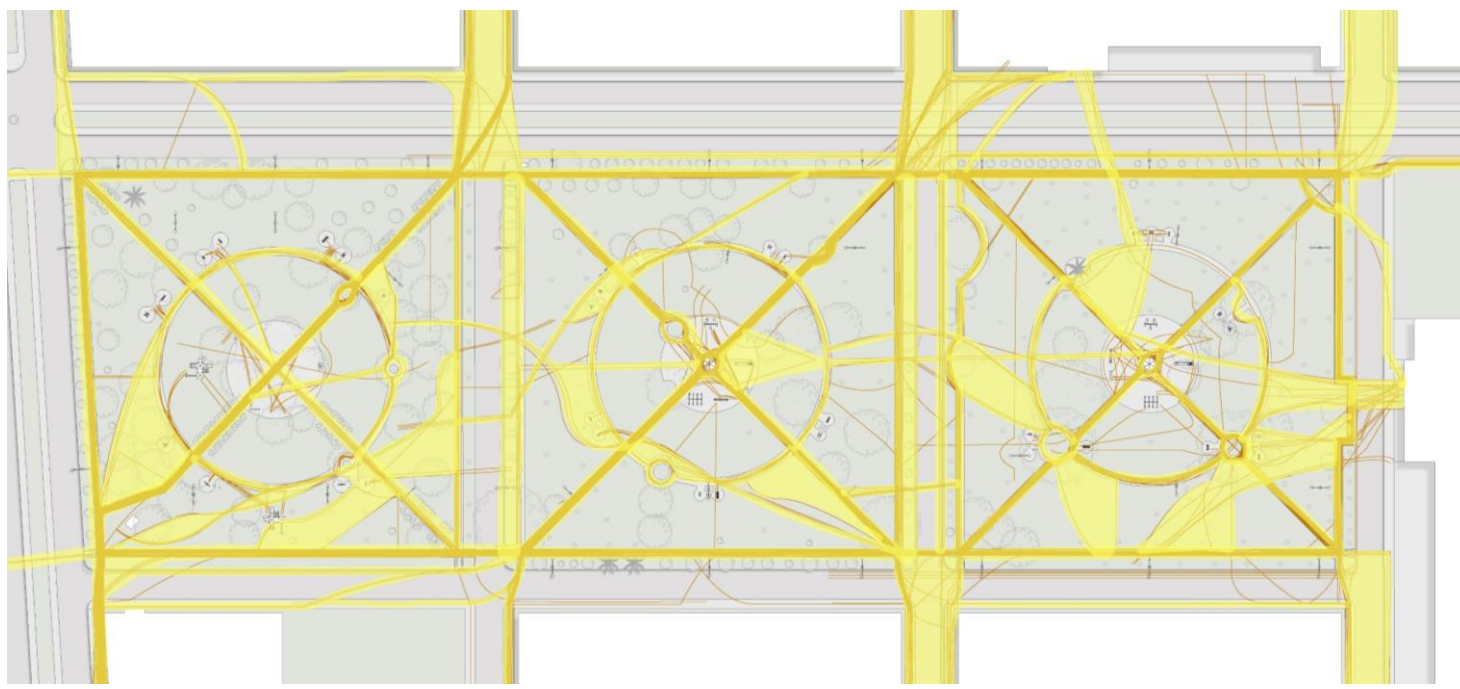
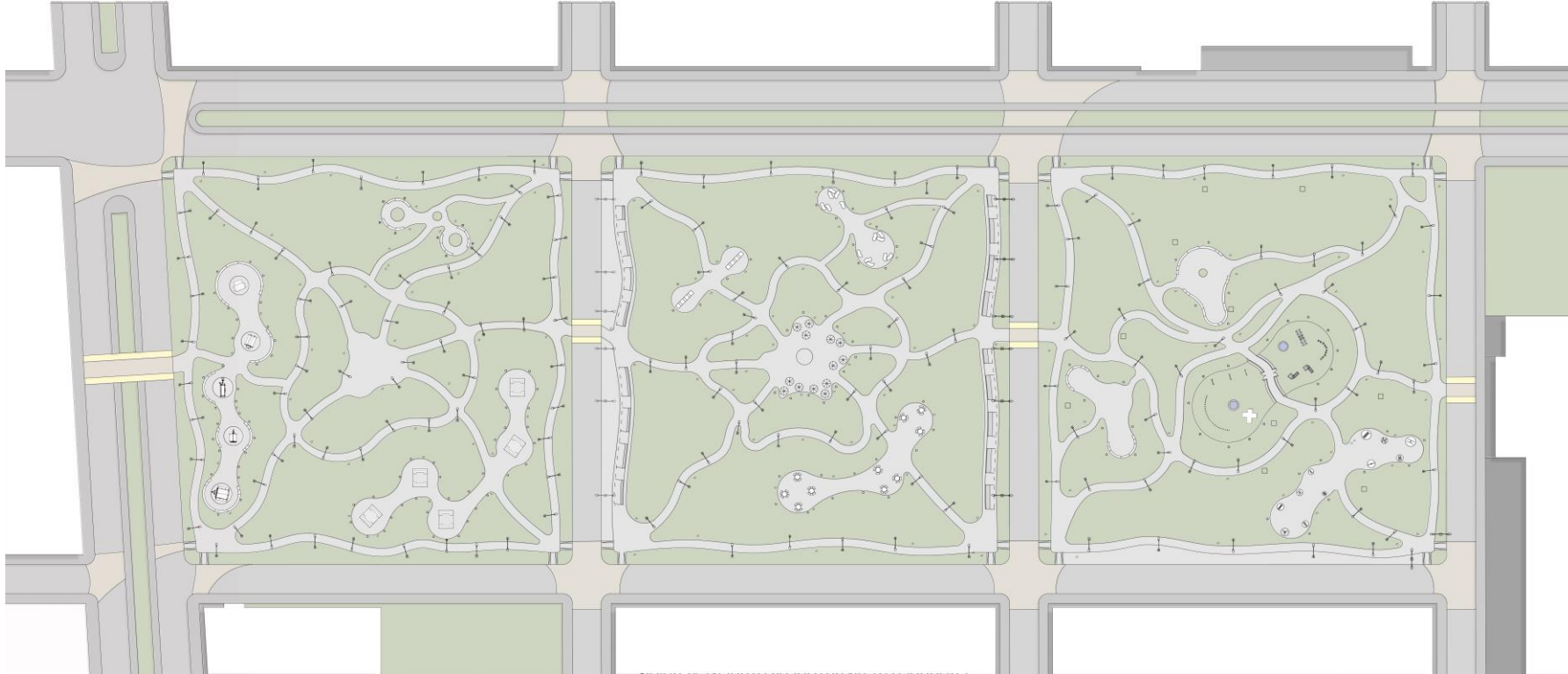

PLANTA DETALLE PASO SEGURO

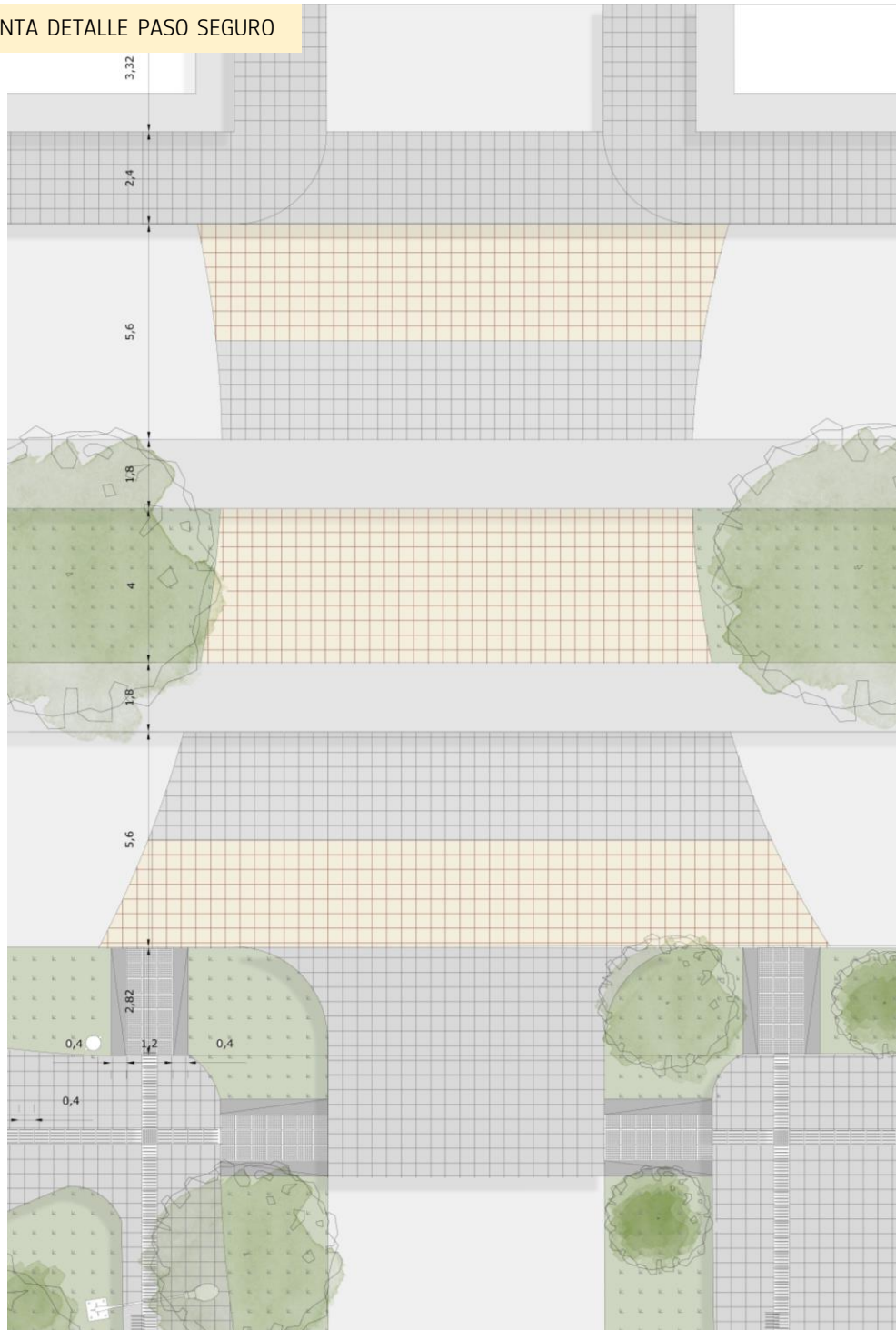

CORTE DETALLE PASO SEGURO



PLANTA DETALLE POMPEYANO

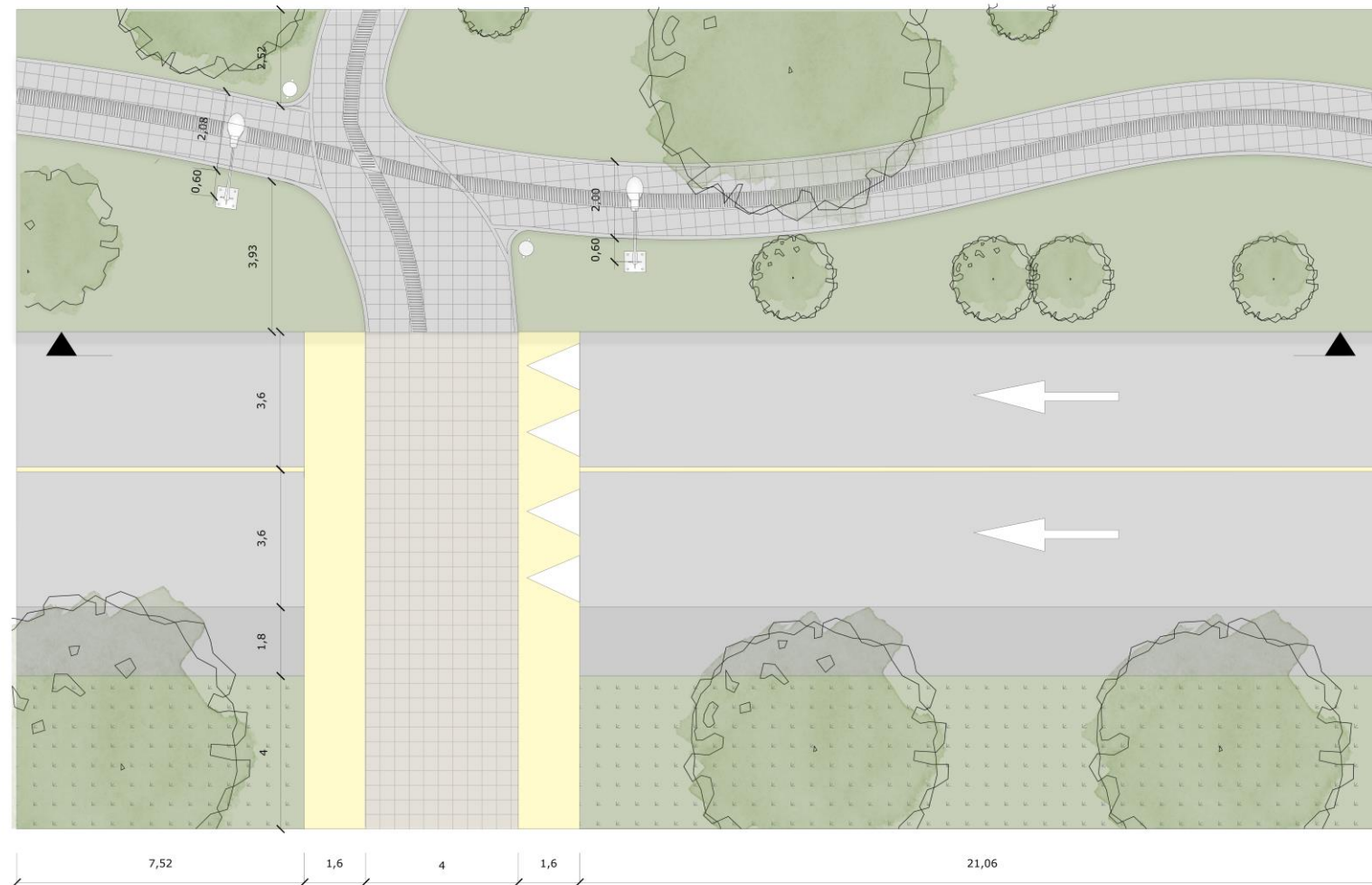

CORTE DETALLE POMPEYANO





PROTOCOLO TRAZABILIDAD



PLANTA PROPUESTA

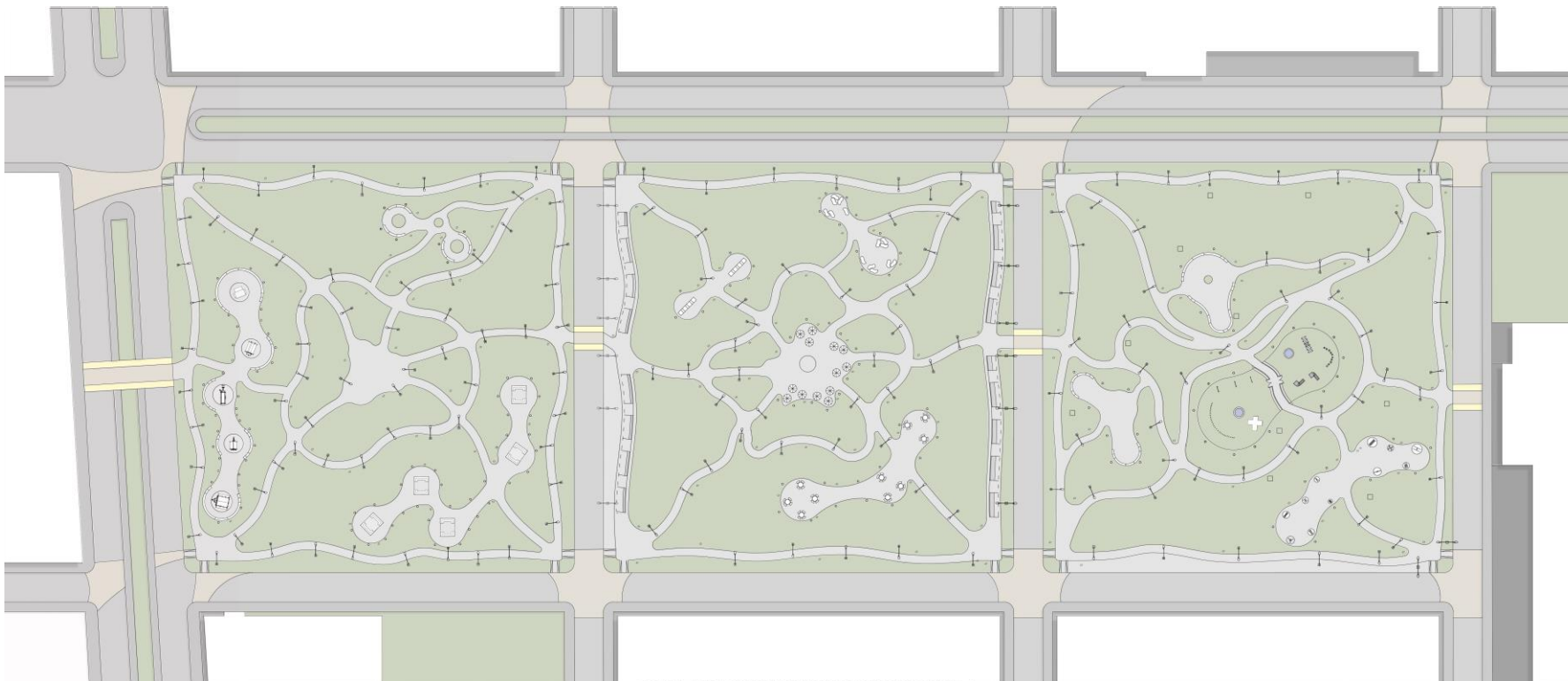

PARQUE I: USOS

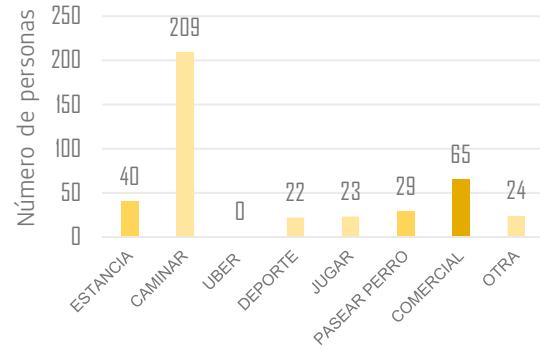

- La actividad más realizada después de caminar es alguna acción relacionada con el uso del comercio con un total de 65 personas de las 412 analizadas.



I. COMERCIAL

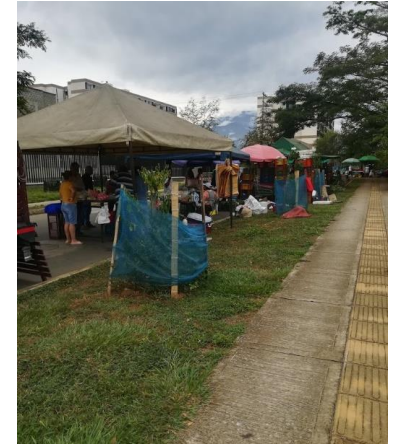

PARQUE 2: USOS

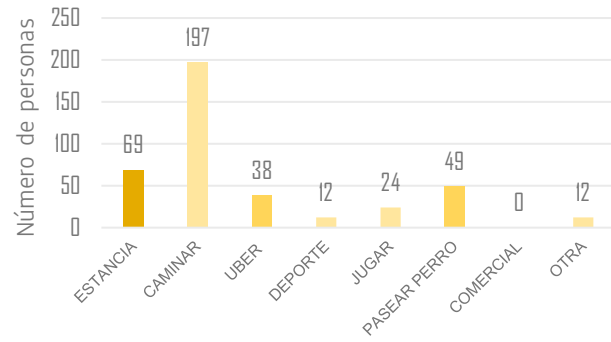

- La actividad más realizada después de caminar es ocupar una estancia con un total de 69 personas de las 401 analizadas.



2. ESTANCIAS

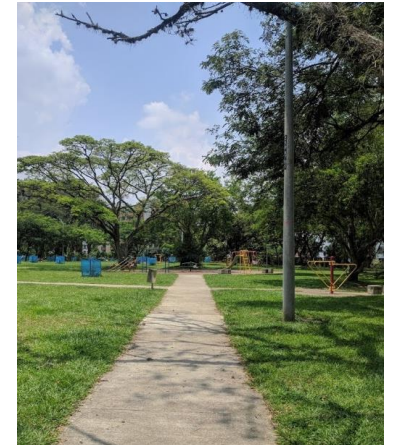

PARQUE 3: USOS

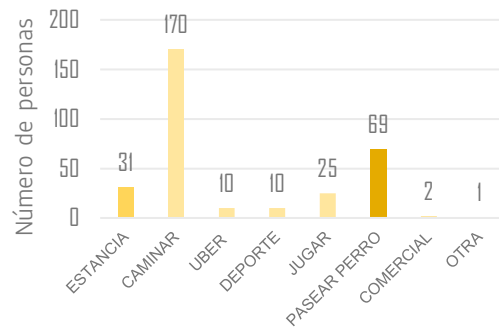

- La actividad más realizada después de caminar es pasear el perro con un total de 69 personas de las 318 analizadas.

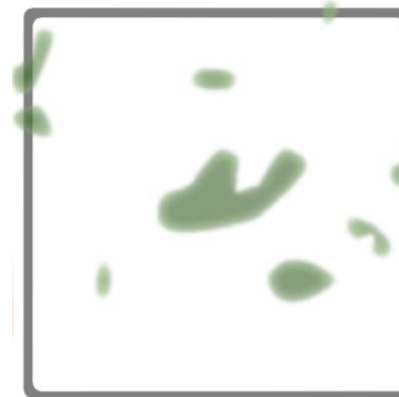

3. PERROS



DIAGRAMA TRAZABILIDAD Y AGLOMERACIÓN



PLANTA PROPUESTA

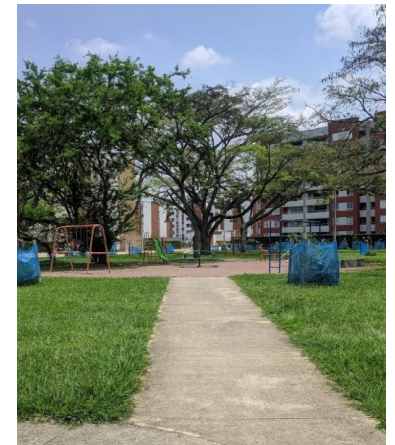
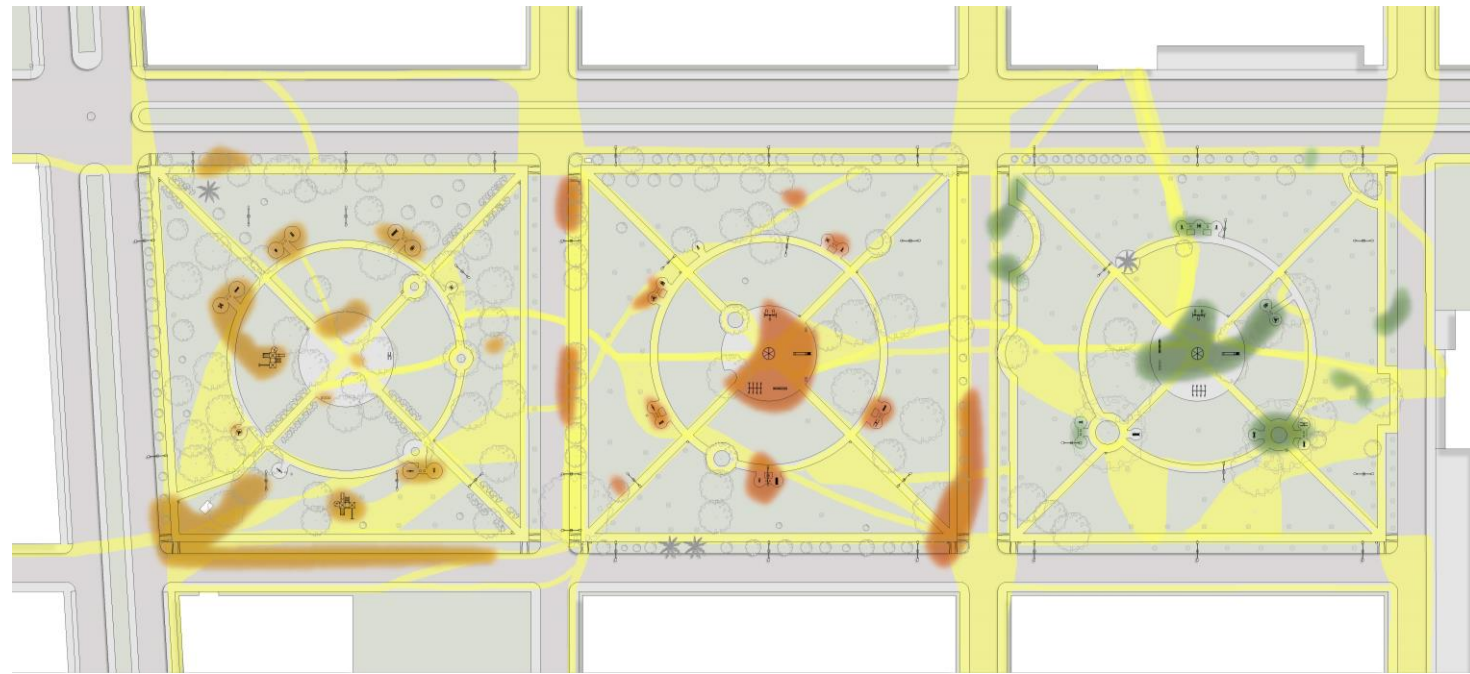
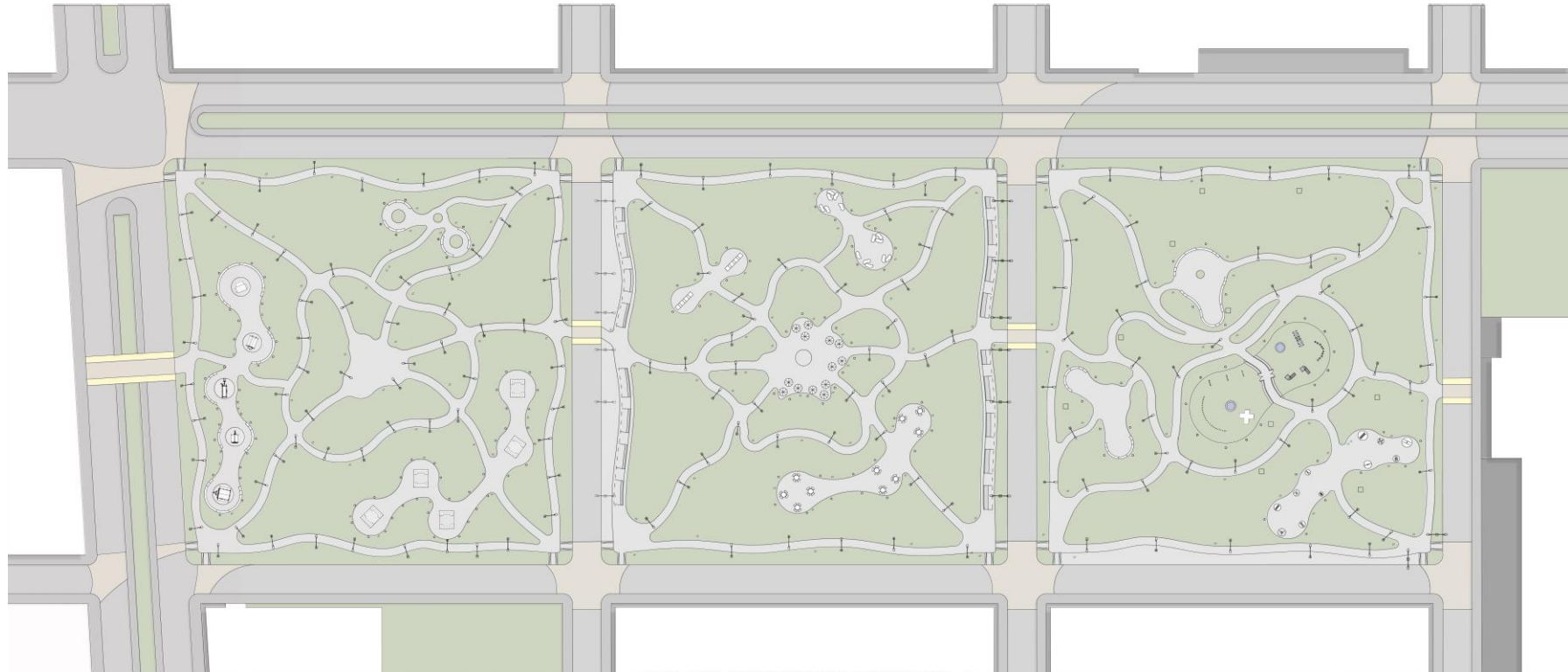

03. DOTACIÓN

ESTANCIAS + LUMINARIA DE PISO Y CESTA

PLANTA DETALLE ESTANCIA TIPO

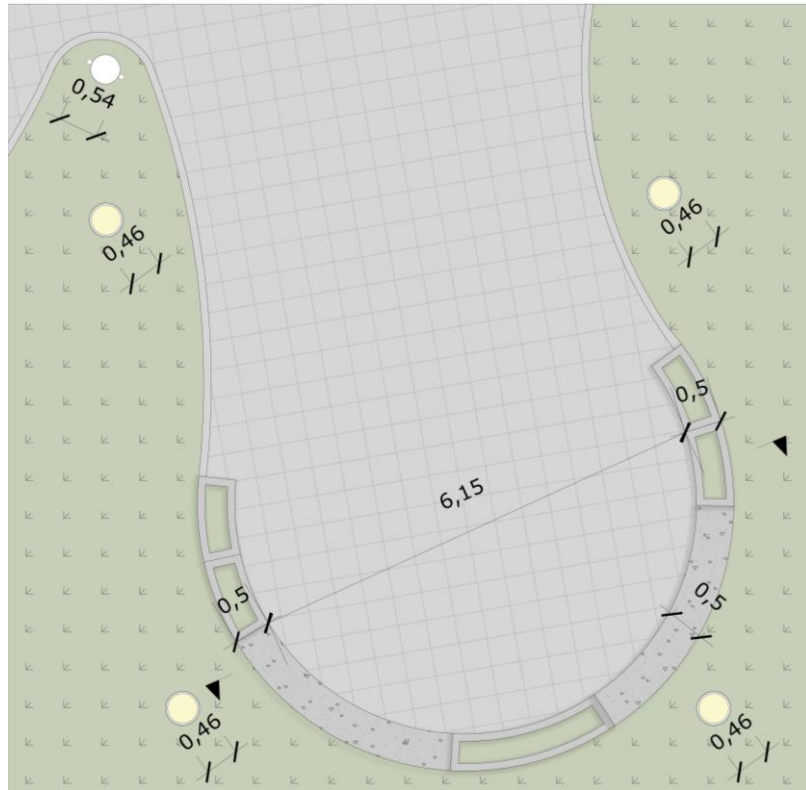

CORTE DETALLE ESTANCIA TIPO

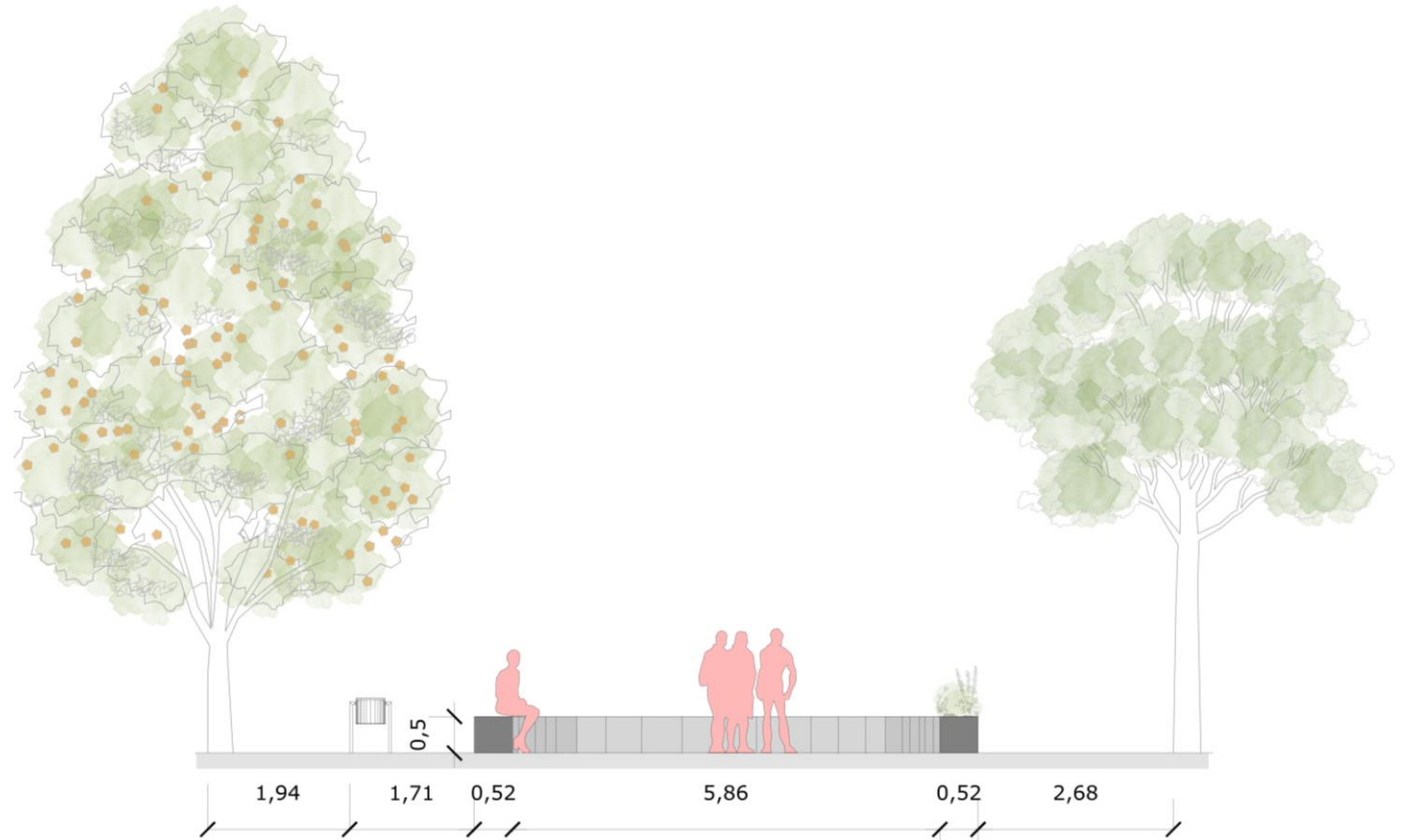

03. DOTACIÓN

ZONA MERCADO LLUVIA DE ORO

1 2 3

PLANTA PARQUE 1



PLANTA ZONA MERCADO

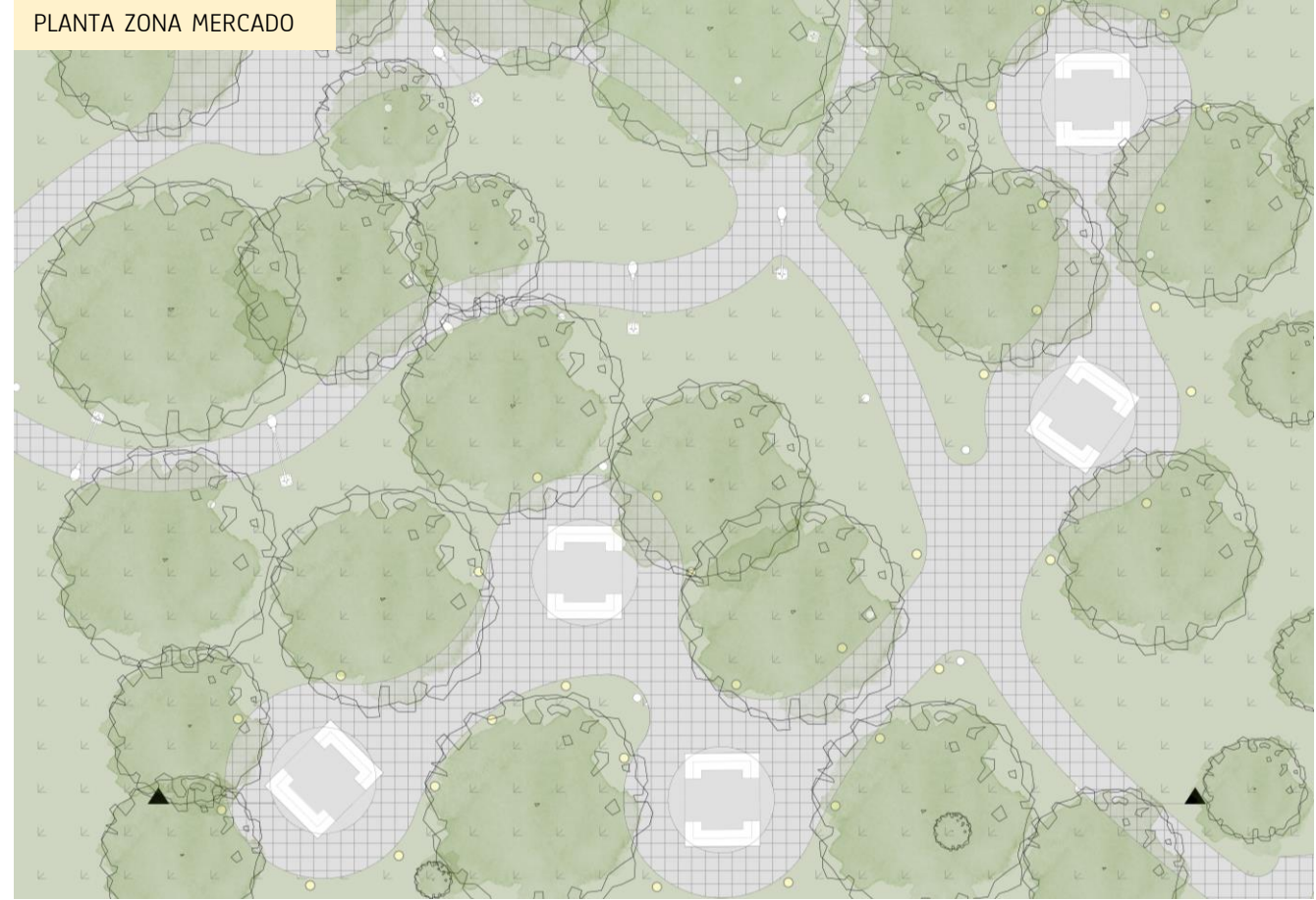

CORTE ZONA MERCADO



03. DOTACIÓN

ZONA MERCADO LLUVIA DE ORO

1

2

3

PLANTA PARQUE 1



PLANTA ZONA MERCADO

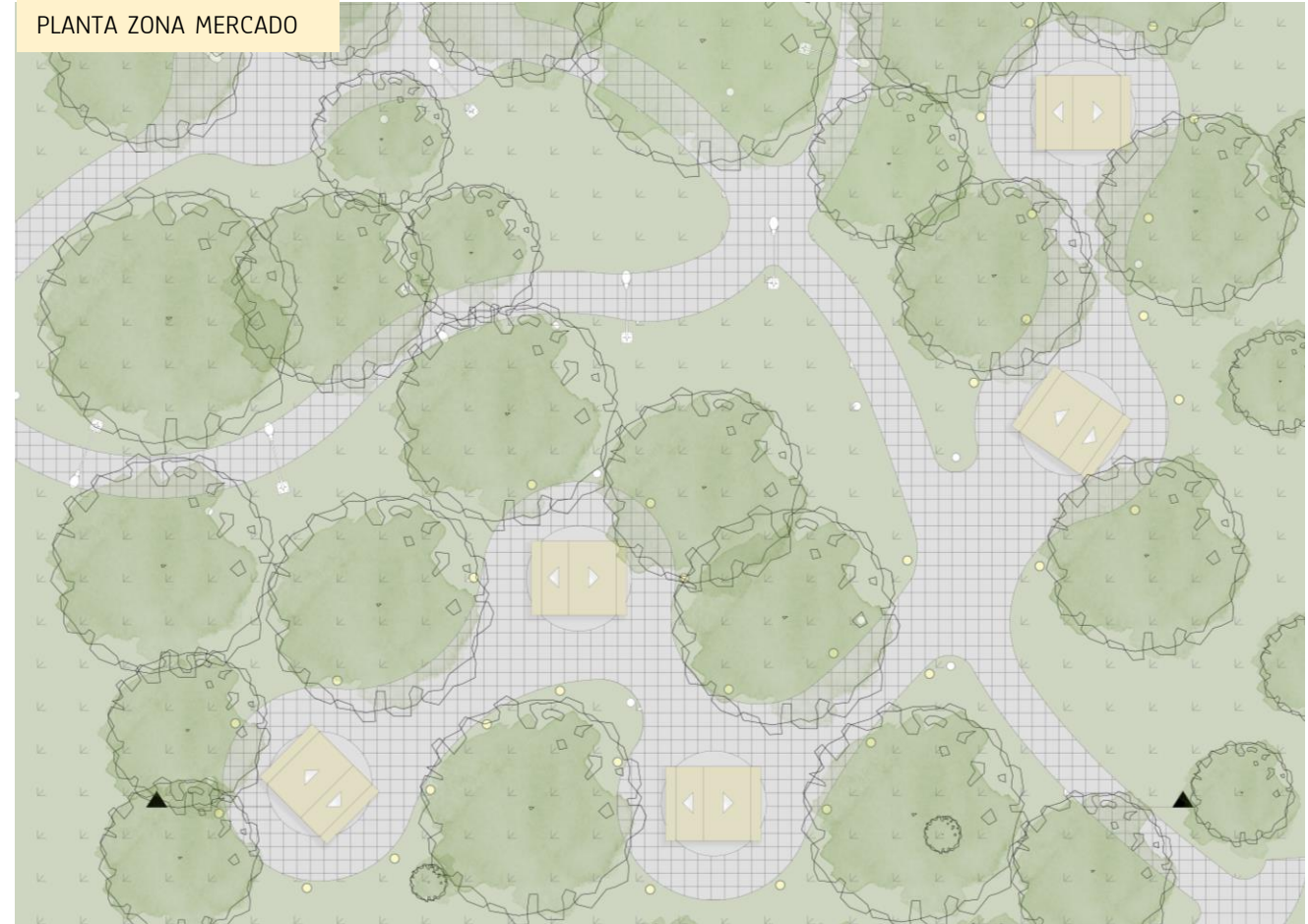

CORTE ZONA MERCADO



03. DOTACIÓN

ZONA MERCADO LLUVIA DE ORO



PLANTA PARQUE 2



PLANTA ZONA MERCADO



CORTE ZONA MERCADO



03. DOTACIÓN
BICITRUCK LOS GUAYACANES



PLANTA PARQUE 2

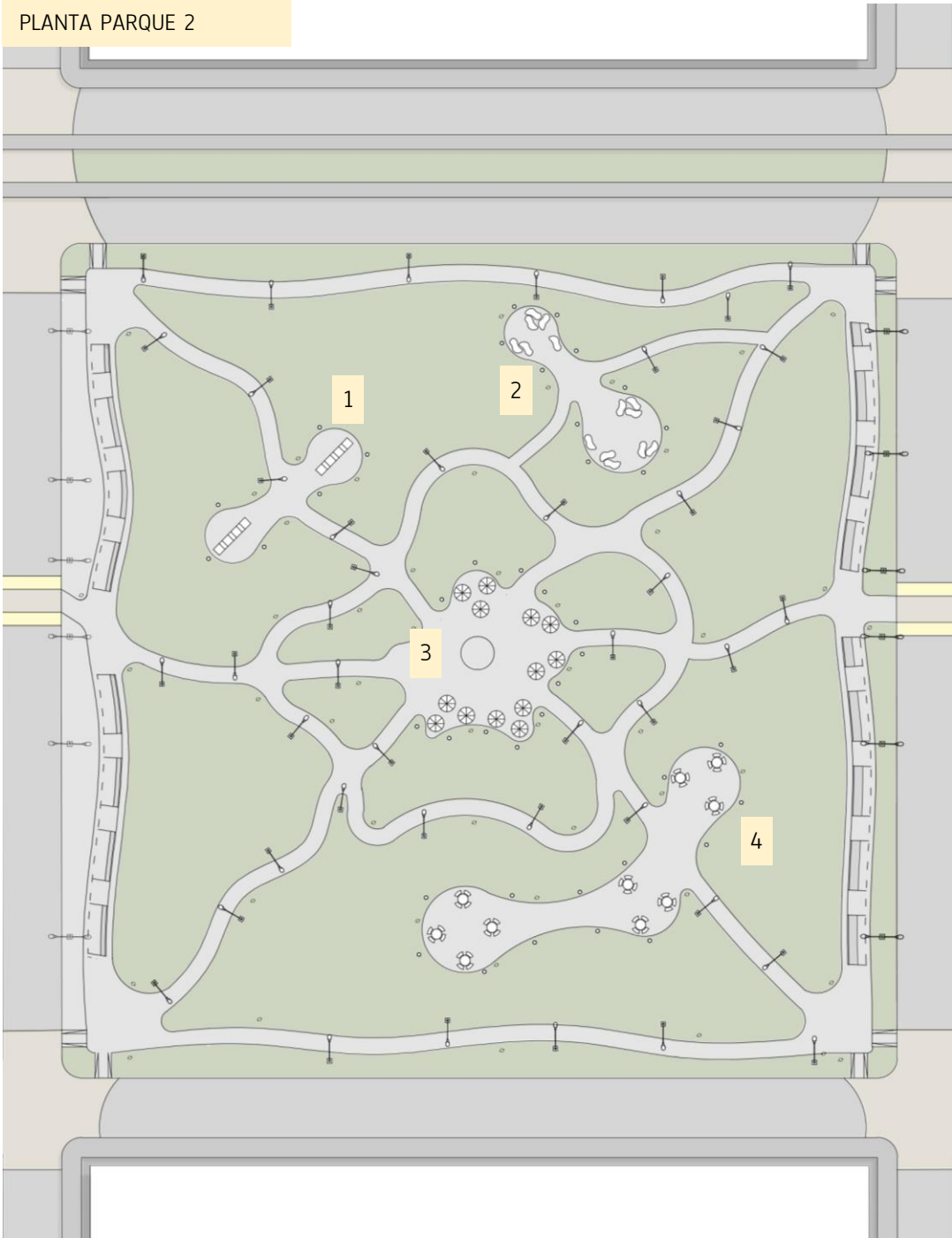

03. DOTACIÓN
PARADERO GUALANDAY



03. DOTACIÓN

PARQUE PERROS FLOR DE REINA

3

2

1

PLANTA PARQUE 3



PLANTA PARQUE PERROS



CORTE PARQUE PERROS



03. DOTACIÓN

PARQUE PERROS FLOR DE REINA

PARQUE PERROS GRANDES

PARQUE PERROS PEQUEÑOS

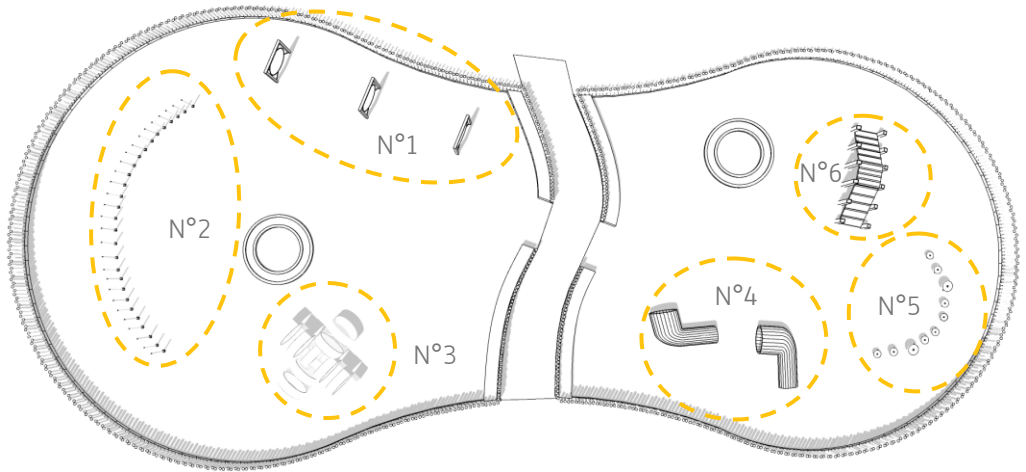
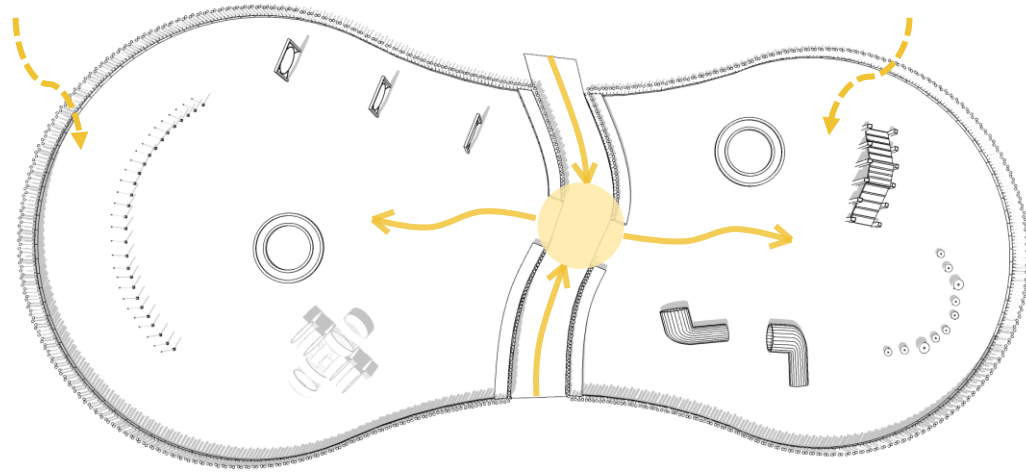

N°1

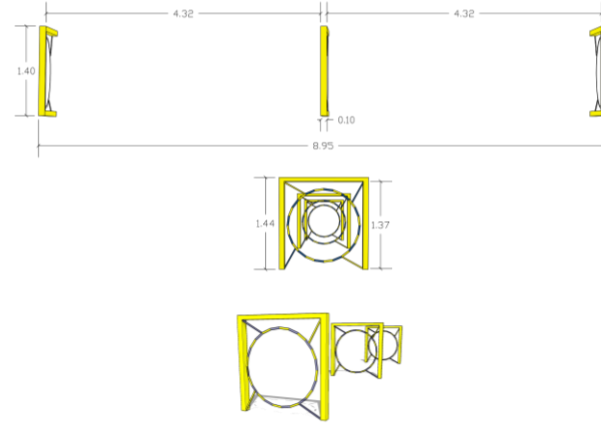

N°2

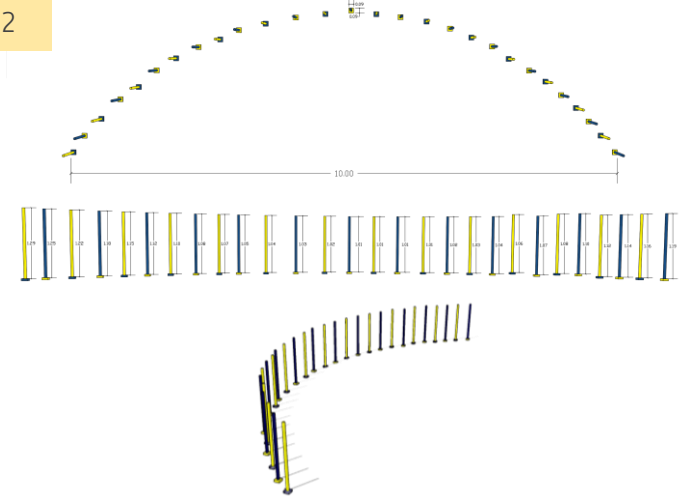

N°3

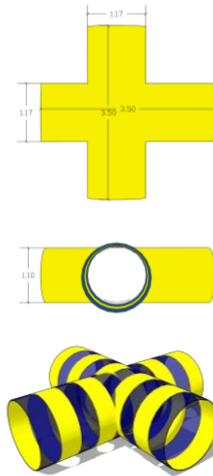

N°4

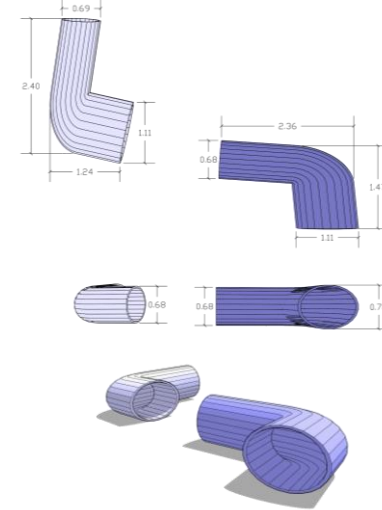

N°5

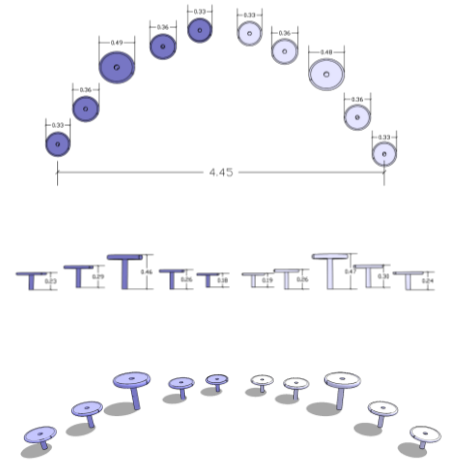

N°6

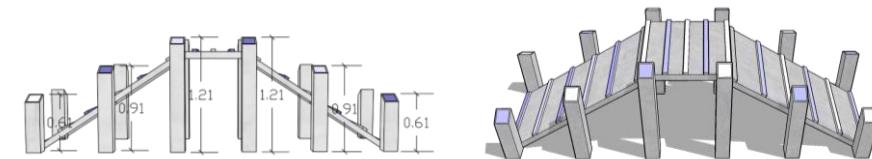
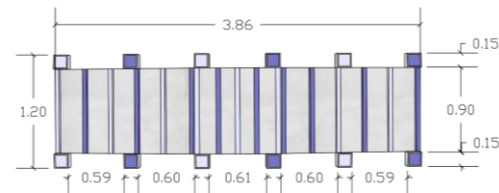

03. DOTACIÓN
PARQUE PERROS FLOR DE REINA

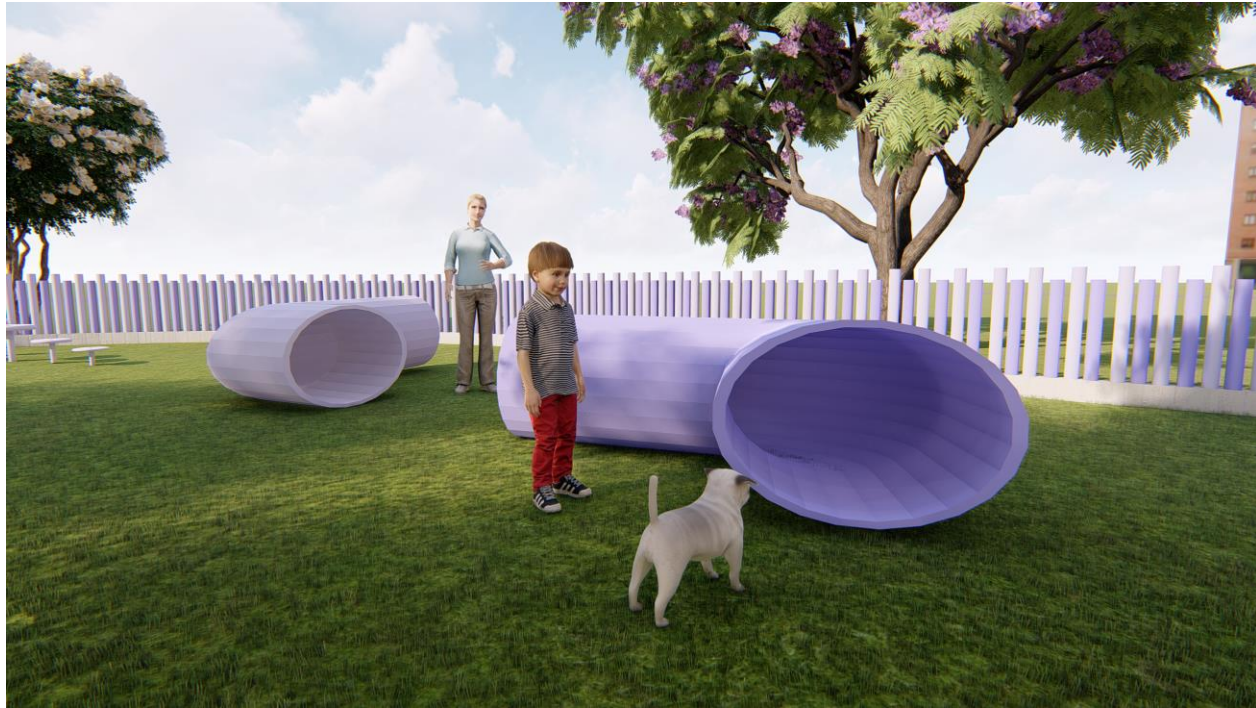

03. DOTACIÓN
PARQUE PERROS FLOR DE REINA





MAPA DE CALOR

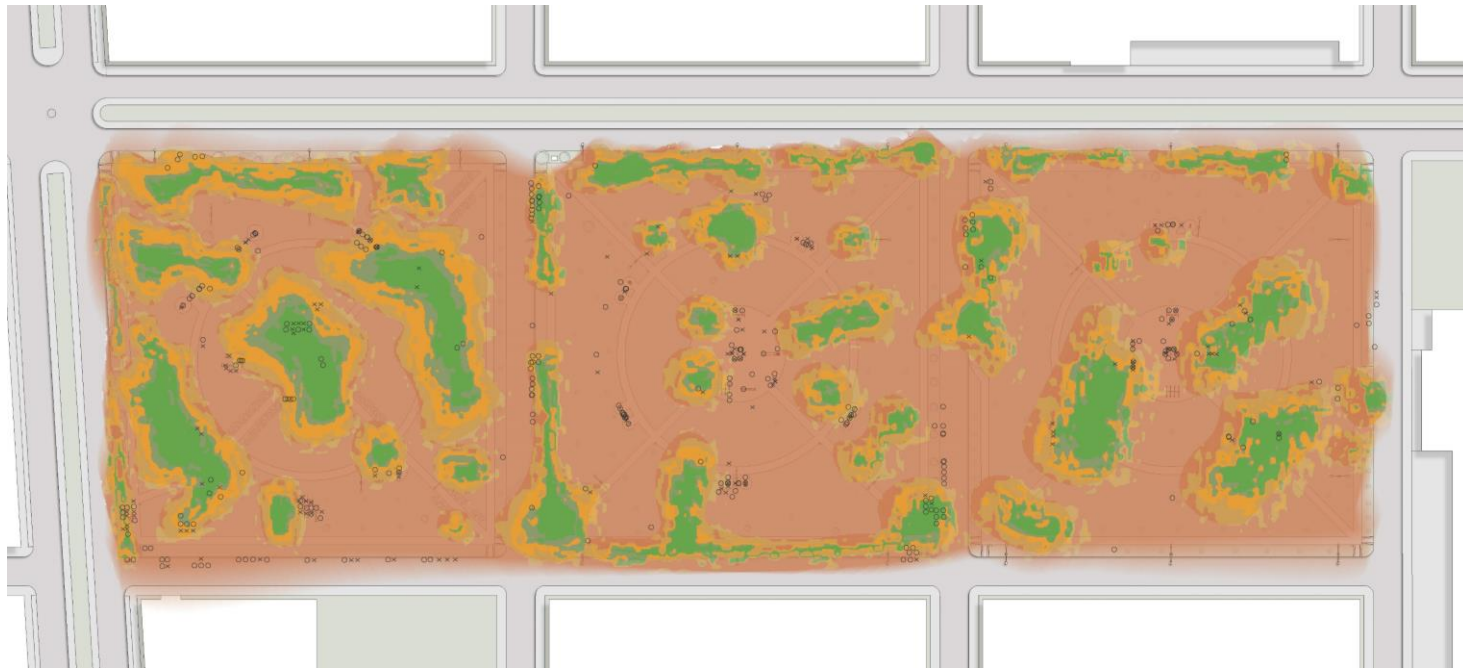

PLANTA PROPUESTA



03. CONFORT
ALCORQUE

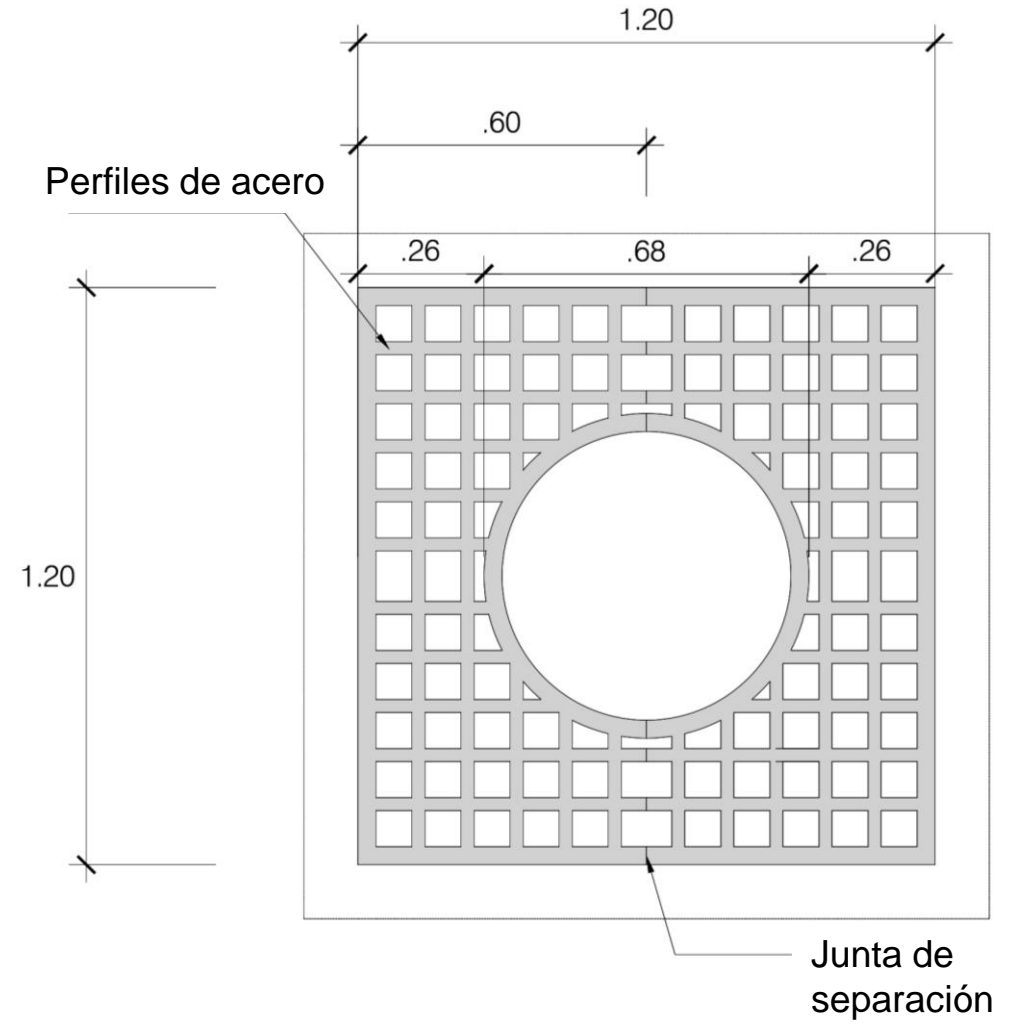
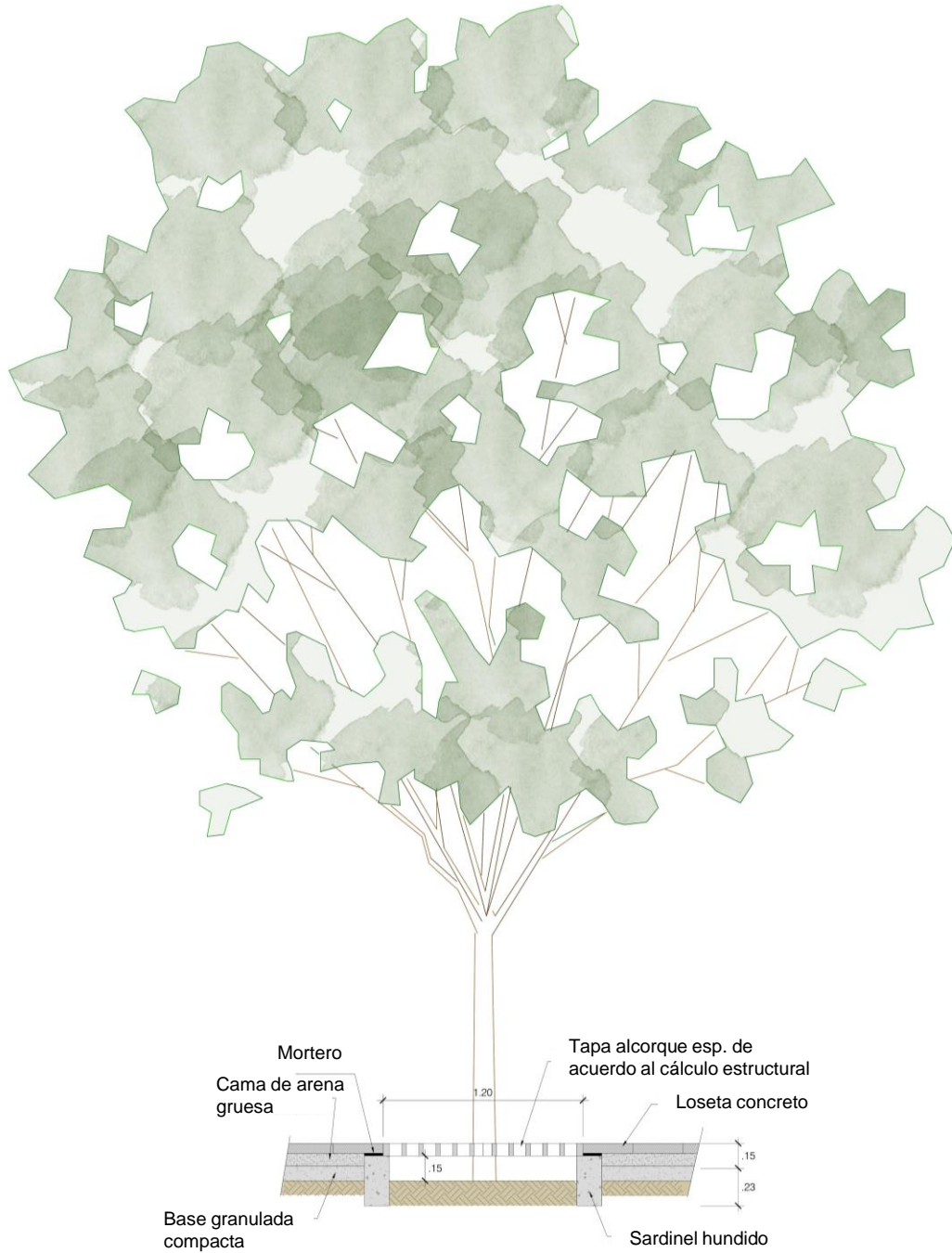

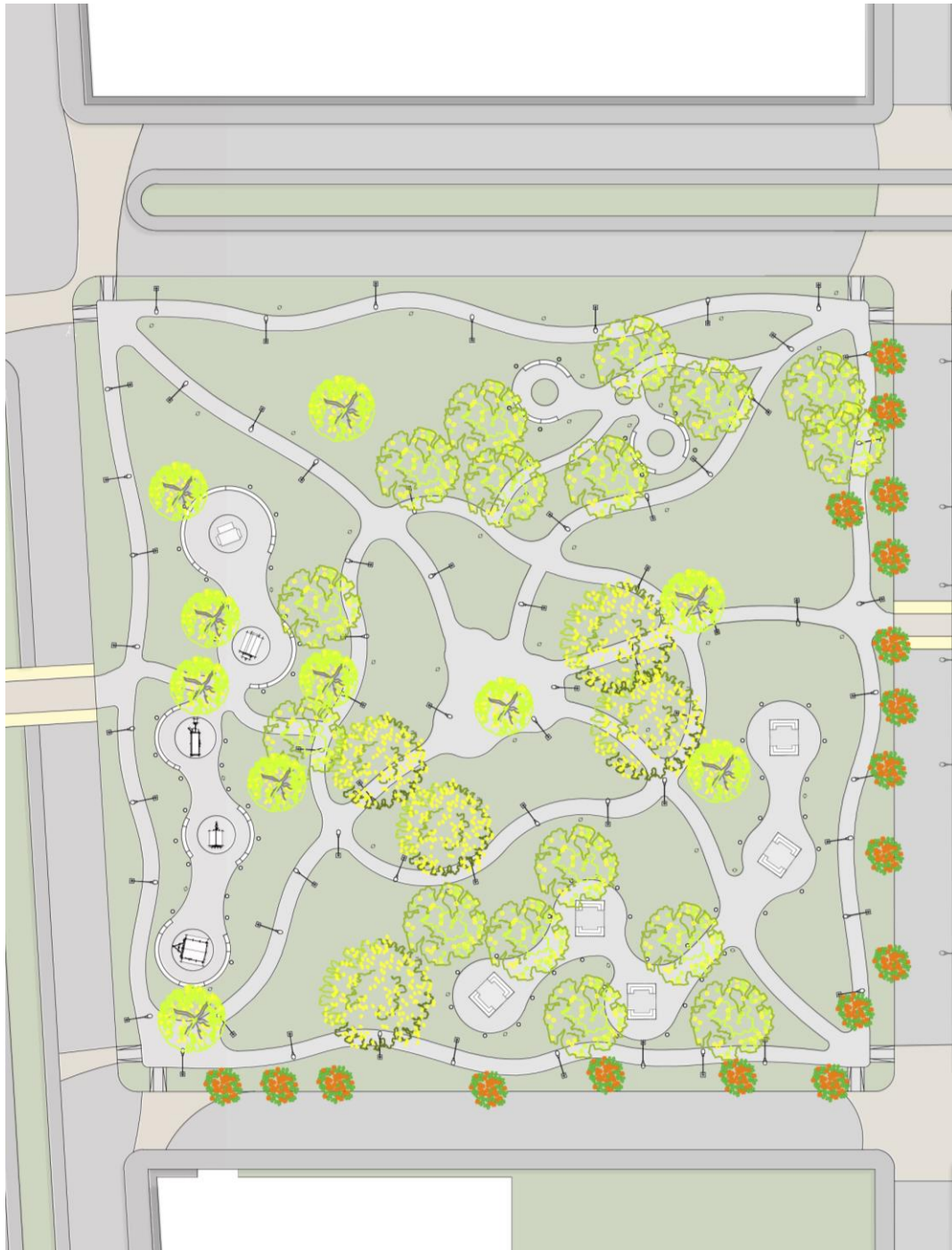

PARQUE I

NOMBRE COMÚN	NOMBRE CIENTÍFICO	INTENCIÓN	IMAGEN
Guayacán amarillo	Tabebuia chrysantha		
Lluvia de oro	Cassia fistula		
Naranja	Citrus aurantium		
Acacia amarilla	Senna siamea		



Control erosión



Especie melífera



Valor espacial



Valor ornamental



Riqueza perceptiva



Nativo



Barrera rompe vientos



Alimento fauna



Sombrío

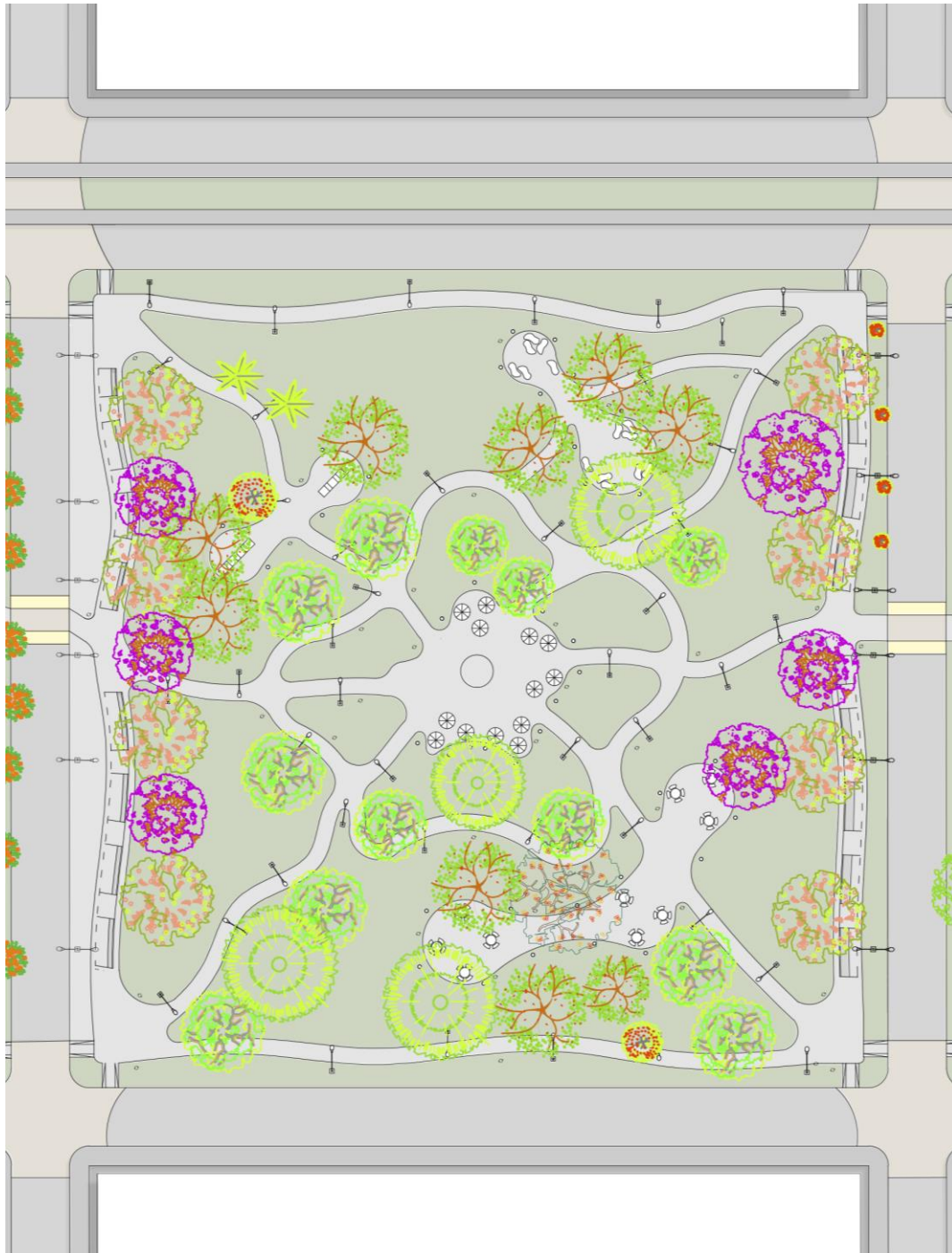

PARQUE 2

NOMBRE COMÚN	NOMBRE CIENTÍFICO	INTENCIÓN	IMAGEN
Calistemon	Callistemon citrinus	 	
Almendro	Terminalia catappa	 	
Árbol de la cruz	Brownea ariza	 	
Ébano ornamental	Geoffroea spinosa	 	
Gualanday	Jacaranda caucana	 	
Guayacán rosado	Tabebuia rosea	 	
Palma roja	Cyrtostachys renda	 	



Control erosión



Especie melífera



Valor espacial



Valor ornamental



Riqueza perceptiva



Nativo



Barrera rompe vientos



Alimento fauna



Sombrío





PARQUE 3

NOMBRE COMÚN	NOMBRE CIENTÍFICO	INTENCIÓN	IMAGEN
Calistemon	Callistemon citrinus		
Amancayo blanco	Plumeria alba		
Flor de reina	Lagerstroemia speciosa		
Acacia amarilla	Senna siamea		



Control erosión



Especie melífera



Valor espacial



Valor ornamental



Riqueza perceptiva



Nativo



Barrera rompe vientos



Alimento fauna



Sombrío





04. PROPUESTA



BIBLIOGRAFÍA

- Alcaldía Santiago De Cali. (2017). Ficha de caracterización socio-económica de los barrios de Santiago de Cali (Diagnóstico Descriptivo). Cali.
- Código Civil de Colombia Artículo 674. (2014). Bienes públicos y de uso público. República de Colombia.
- Delgado, M. (2003). Naturalismo y realismo en etnografía urbana. Revista Colombiana de Antropología , 19.
- Departamento Administrativo de Planeación Municipal . (2014). Plan de desarrollo Bochalema. Plan de ordenamiento territorial.
- Organización Mundial de la Salud. (2011). Colombia, con menos metros de espacio público por habitante. Portafolio.
- Alcaldía de Santiago de Cali, Departamento Administrativo de Planeación Municipal. (2017). Manual de elementos complementarios del espacio público, MECoEP. Cali.
- Alcaldía de Santiago de Cali, Departamento Administrativo de Planeación Municipal. (2018). Manual de adecuación del espacio público efectivo MaEPE. Cali.

GRACIAS

¿Preguntas?

CREDITS: This presentation template was created by **Slidesgo**, including icons by **Flaticon**, and infographics & images by **Freepik** and illustrations by **Stories**

